

▼ From left to right: ATM4, ATM9, ATM2



The Faster, Simpler and Safer Way to Align Flanges



Adjustable Reach

The highly adjustable reach of the wing and drop leg on the ATM4 and ATM9 allows precise alignment.



Gauge and Adaptor

The ATM9 includes P142 hand pump and HC7206C 6 ft. long hose. Enerpac recommend the use of the pressure gauge **GP10S** and gauge adaptor **GA4** for easy mounting of the gauge onto your system or use GA45GC Gauge Adaptor Assembly.

- Enerpac ATM-Series tools rectify twist and rotational misalignment quickly, safely, and without the need for an external power source
- Appropriate for use on most ANSI, API, BS and DIN flanges
- No slings, hooks or lifting gear required
- Can be installed and used in any position (horizontally or vertically)
- Portable, lightweight design enables easy transport and use, even in remote locations
- Stays stable in position under full load
- Reduces set-up time: no need for chains, pulleys or rigs
- Safety strap helps provide secure operation
- Each ATM-model contains a tool and kit box

▼ The compact ATM2 is actuated by simply hand turning the crank.



▼ The ATM9 is shown here with optional pressure gauge and gauge adaptor.





Applications

Enerpac ATM-Series Tools help correct flange misalignment, and allow bolts to be placed into joints. This alignment takes place during pipework construction, or maintenance.

These tools provide pipe installers and maintenance personnel with some of the simplest, safest and most productive solutions available for flange alignment in the market today.

- ① Extendable wing provides usage on wide variety of flanges.
- ② Portable, light weight design enables easy transport and use.
- ③ Hand-adjustable base for easy positioning by a single operator.
- ④ Safety strap helps provide secure operation from a horizontal or vertical position.

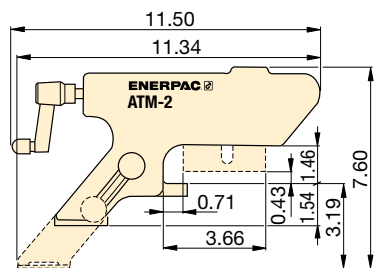
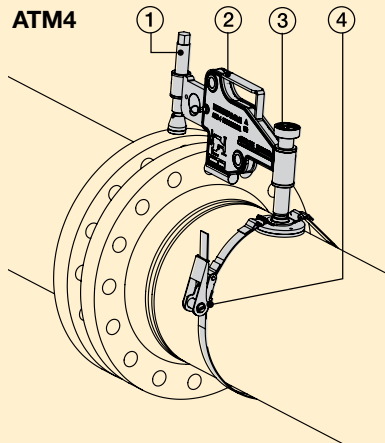

ATM2

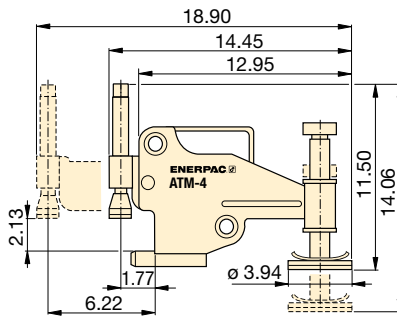

ATM4

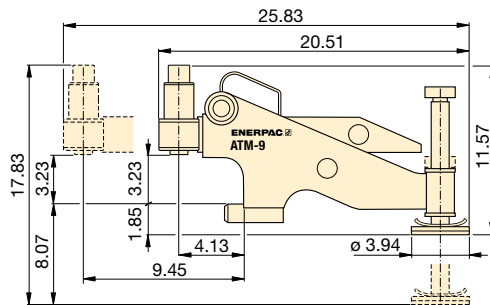

ATM9

Maximum Lifting Force (ton)*	Maximum Lifting Force (kN)*	Model Number	Minimum Bolt Size**		Flange Wall Thickness (max)		Wt. (lbs)
			(in)	(mm)	(in)	(mm)	
1	10	ATM2	0.63	16	0.55 - 3.29	14 - 82	3.5
4	40	ATM4	0.95	24	1.18 - 5.23	30 - 133	19
10	90	ATM9**	1.40	35,5	3.66 - 9.00	93 - 228	32

* At 10,000-psi maximum operating pressure.

** ATM9 includes an Enerpac hand pump and hydraulic hose (gauge and adaptor sold separately). ATM9 weight includes tool only.

ATM Series



Minimum Bolt Size:

0.63 - 1.40 inches

Flange Wall Thickness:

0.55 - 9.00 inches

Maximum Lifting Force:

1 - 10 tons



Cylinder-Pump Sets

Hydraulic cylinders, jacks and lifting wedges can also be used to assist in pipe line positioning and aligning.

Page: 63



Pipe Flange Face Tool

The portable, hand powered tool FF120 makes even the hardest to reach pipe flanges resurfaceable in a safe and convenient way.

Page: 340

▼ The ATM-Series – the faster, simpler and safer way to align flanges.

