

Get buckets and loaders back to work with effective on-site repairs.

If you have ever repaired worn hinge points on loader arms or buckets, you know how difficult it is to cut off the worn area and try to weld on new hinge points while keeping everything lined up. A better way is to use the Climax Model BB3000 Portable Boring Machine. If the holes are not badly damaged, you can simply weld them up, attach the Climax Portable Boring Machine, and re-bore them to original dimensions. If the hinge points are so damaged that the entire area needs to be replaced, weld on new sections with slightly undersized holes, then quickly re-bore them to original dimensions while keeping everything in proper alignment.



Boring Capacity

- Bore from 1-½ - 5 inches (38.1 - 127.0 mm) in diameter, using the bar and tool head.
- The 1-¼ inch (31.75 mm) diameter bar is available in almost any length in 1 foot (304.8 mm) increments.
- Holes are positioned at 6 or 10 inch (152.4 or 254.0 mm) intervals along the bar to hold 3/8 inch square tool bits in the SAE inch version, and 10 mm square tool bits in the metric version.
- The clamp-on tool head covers the 3-¼ - 5 inch (76.2 - 127.0 mm) diameter range.

Powerful

- 1.0 Hp (0.74 kW), universal type motor drives a 7.5:1 reduction gear box; produces up to 90 ft-lbs (122 N•m) of torque at the bar.
- Two-speed motor has bar speeds ranging from 52 - 88, and 89 - 185 no load, freespeed rpm; 2 - 2.2 amps.
- Metal removal rate of up to 1 cubic inch/min (16.4 cm³/min) in C1018 steel.

Compact Design

- The rotational drive extends only 19 inches (482.6 mm) out from the mounting bracket and 14 inches (355.6 mm) from the bar to

the top of the motor. The rotational drive can be mounted with the motor in any position around the bar if clearance is a problem.

- Rotational drive with feed rack and anti-torque scissors weighs only 35 lbs. (15.9 kg).

Automatic Power Feed

- Infinitely variable, reversible power feed has a 10 inch (254.0 mm) stroke. An automatic feed stop mechanism disengages the feed at the end of the 10 inch stroke.
- Feed rate is from 0 - 0.018 inches (0 - 0.46 mm) per revolution.

OPERATIONAL DIMENSIONS

Dimensions in Inch (mm)

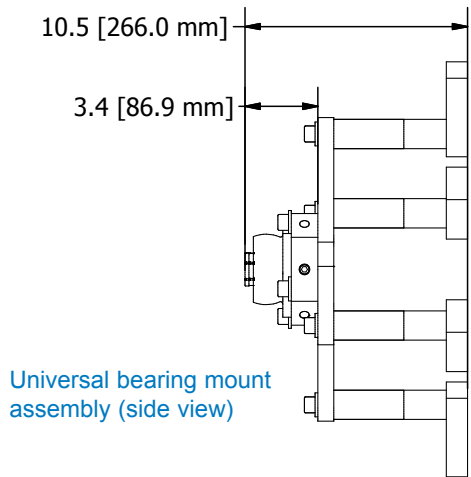

Universal bearing mount assembly (side view)

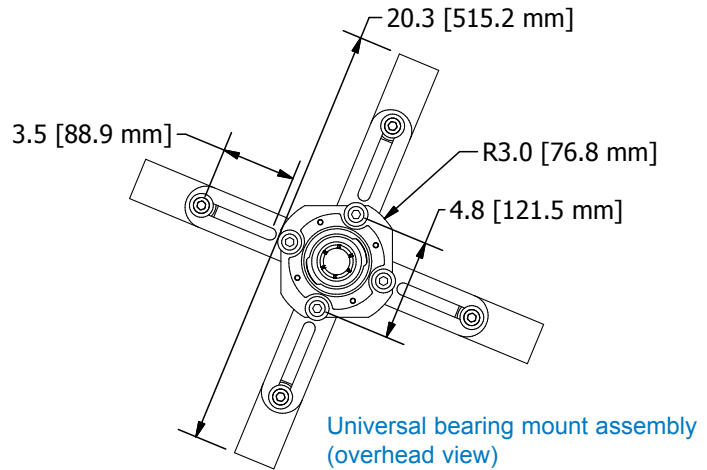

Universal bearing mount assembly (overhead view)

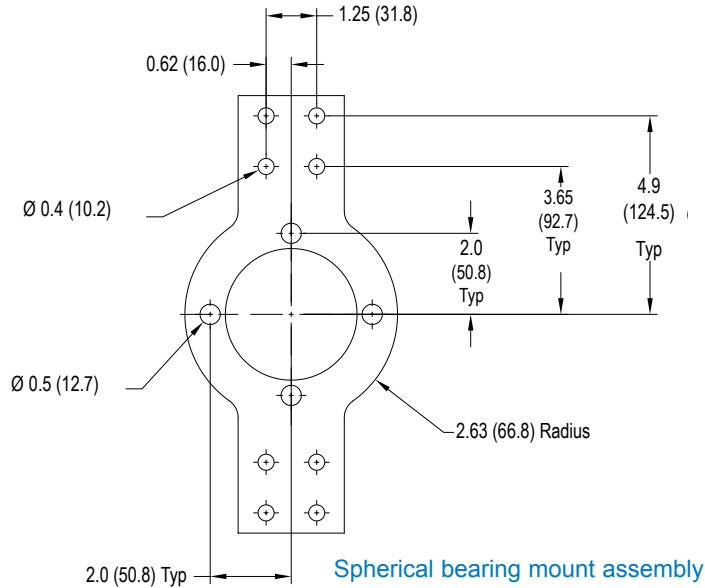

Spherical bearing mount assembly

NOTE: Dimensions typical for both arms

First hole is 1 inch (25.4 mm) from the end of the bar.

Holes in this example are spaced 10 inches (254.0mm) apart. Other hole spacing is available.

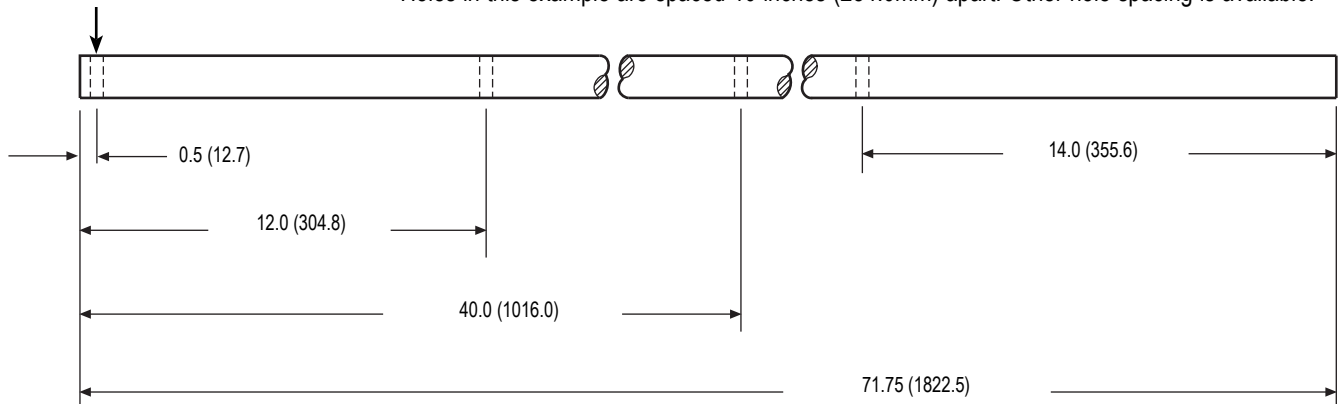

Sample boring bar braached hole locations (72 inch (1828.8 mm) bar only)

OPERATIONAL DIMENSIONS

Dimensions in Inch (mm)

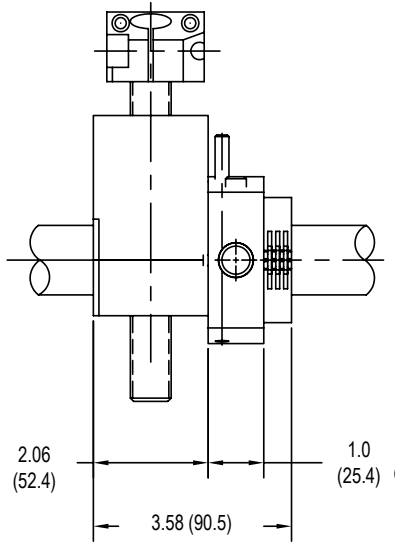

Facing Head, side view
and side view (right)

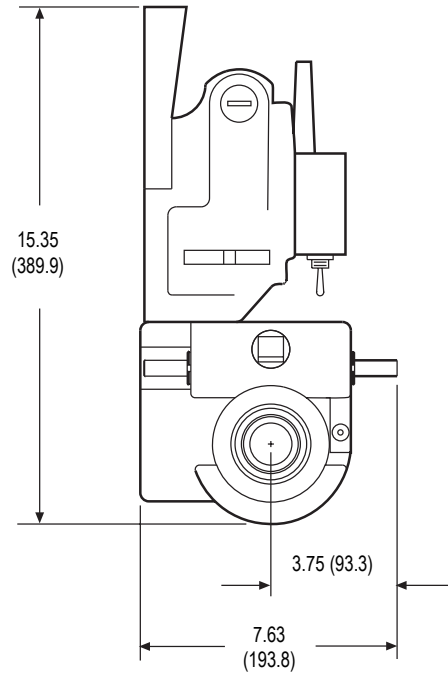

Rotational drive assembly

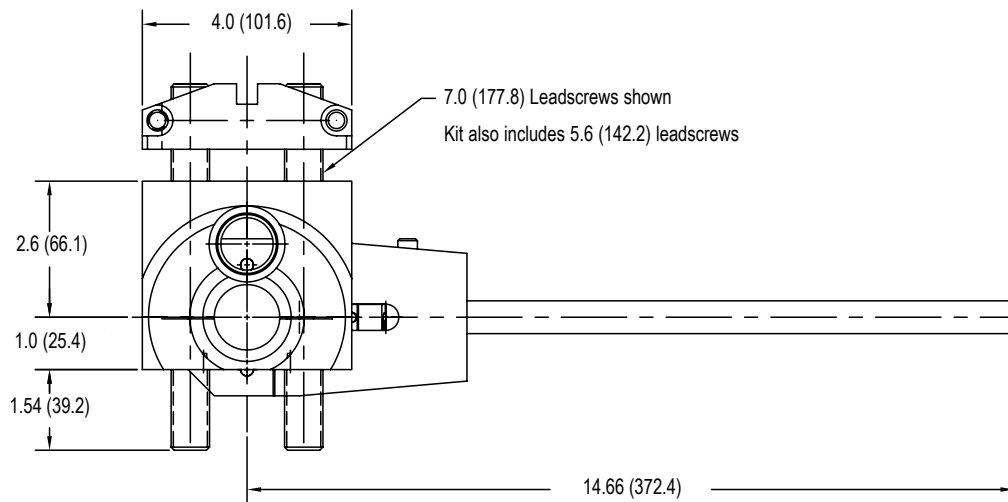

Facing Head, overhead view

TOOL CONFIGURATIONS

Configure your BB3000 in 5 easy steps:

To configure your BB3000 Boring Machine:

- 1 Select a Base Unit
- 2 Select a Boring Bar
- 3 Select a Drive Motor Option
- 4 Select Setup Cones
- 5 Select a Mounting Option

To generate the correct part number for the boring machine you require, simply select the part number needed in each step, and contact your Climax representative.

The Base Unit includes the RDU, tool kit, tool head, packaging, and instruction manual. The unit comes packed in a durable metal container.

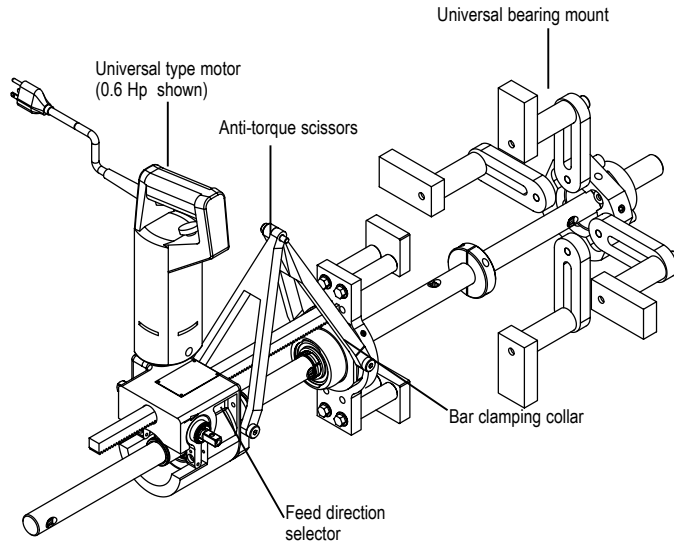

1 Base Unit

Standard Inch Unit	37453
Standard Metric Unit	37493

2 Boring Bar, 1-1/4 inch dia.

Holes spaced every 6 inches (152.4 mm)

48 inch, 3/8 inch holes	43657
72 inch, 3/8 inch holes	43658
96 inch, 3/8 inch holes	43659
48 inch (1219.2 mm), 10 mm holes	43640
72 inch (1828.8 mm), 10 mm holes	43641
96 inch (2438.4 mm), 10 mm holes	43642

* Multiple units may be ordered.

Boring Bar, 1-1/4 inch dia.

Holes spaced every 10 inches (254 mm)

48 inch, 3/8 inch holes	43651
72 inch, 3/8 inch holes	43652
96 inch, 3/8 inch holes	43653
48 inch (1219.2 mm), 10 mm holes	43634
72 inch (1828.8 mm), 10 mm holes	43636
96 inch (2438.4 mm), 10 mm holes	43629

* Multiple units may be ordered.

3 Drive Motor

Electric, 120 VAC Speed Control, 65/92 bar rpm, 1 speed for 1 Hp motors	33658
--	-------

Electric, 230 VAC Speed Control, 65/92 bar rpm, 1 speed for 1 Hp motors	29380
--	-------

Electric, 120 VAC Speed Control, 52/185 bar rpm, 2 speed for 1 Hp motors	37459
---	-------

Electric, 230 VAC Speed Control, 52/185 bar rpm, 2 speed for 1 Hp motors	37460
---	-------

Electric, 120 VAC Speed Control 86 rpm reversible	19567
--	-------

Pneumatic, 175 rpm for 0.6 Hp motor (includes air conditioning unit)	37085
---	-------

* Multiple units may be ordered.

4 Setup Cones

Small: 1/2 – 3/4 inch (38.1 – 82.6 mm) dia.	26263
---	-------

Large: 3/4 – 5 inch (82.6 – 127.0 mm) dia.	26264
--	-------

Full Set: 1/2 – 5 inch (38.1 – 127.0 mm) dia.	27803
---	-------

5 Mounting Option

Double arm mount	24756
------------------	-------

Universal mount	36961
-----------------	-------

ID mounting kit	37621
-----------------	-------

* Multiple units may be ordered.

ACCESSORIES

Further customize your BB3000 Boring Machine with these main boring bar options.
Order separately (special customized bars available upon request)



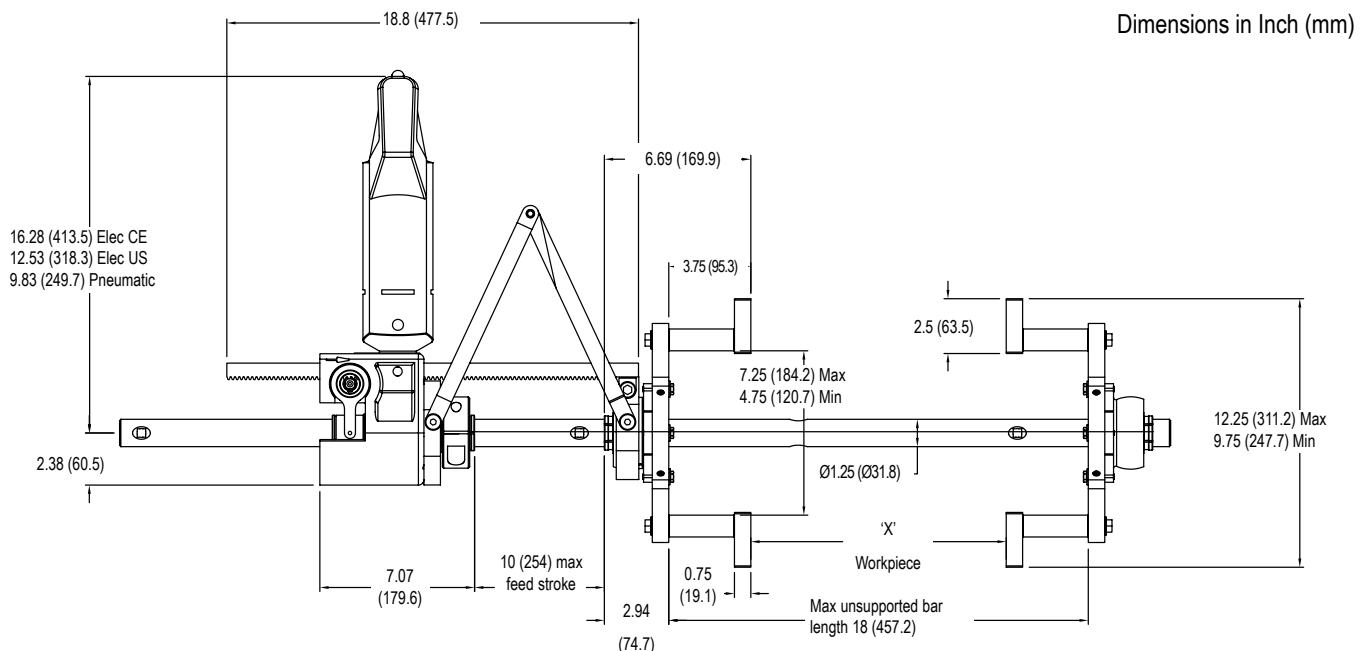

- All bars are 1-¼ inch (31.8 mm) in diameter, and made of 1045 S-CPO chrome-plated steel.
- After machining, bars are straightened.
- Bars come packaged in a fitted steel container with quick-release latches.
- First hole is 1 inch from the end of the bar, for all bar lengths and hole spacing.

Part Number	Bar Length		Hole Size	Hole Spacing	
	Inches	mm		Inches	mm
43650	36 inches	914.4 mm	3/8 inch	10 inches	254.0 mm
43651	48 inches	1219.2 mm	3/8 inch	10 inches	254.0 mm
43652	72 inches	1828.8 mm	3/8 inch	10 inches	254.0 mm
43653	96 inches	2438.4 mm	3/8 inch	10 inches	254.0 mm
43654	120 inches	3048.0 mm	3/8 inch	10 inches	254.0 mm
43655	144 inches	3657.6 mm	3/8 inch	10 inches	254.0 mm
43633	36 inches	914.4 mm	10 mm	10 inches	254.0 mm
43634	48 inches	1219.2 mm	10 mm	10 inches	254.0 mm
43636	72 inches	1828.8 mm	10 mm	10 inches	254.0 mm
43629	96 inches	2438.4 mm	10 mm	10 inches	254.0 mm
43637	120 inches	3048.0 mm	10 mm	10 inches	254.0 mm
43638	144 inches	3657.6 mm	10 mm	10 inches	254.0 mm
43656	36 inches	914.4 mm	3/8 inch	6 inches	152.4 mm
43657	48 inches	1219.2 mm	3/8 inch	6 inches	152.4 mm
43658	72 inches	1828.8 mm	3/8 inch	6 inches	152.4 mm
43659	96 inches	2438.4 mm	3/8 inch	6 inches	152.4 mm
43639	36 inches	914.4 mm	10 mm	6 inches	152.4 mm
43640	48 inches	1219.2 mm	10 mm	6 inches	152.4 mm
43641	72 inches	1828.8 mm	10 mm	6 inches	152.4 mm
43642	96 inches	2438.4 mm	10 mm	6 inches	152.4 mm

Here's how to determine the length of the boring bar you will require:

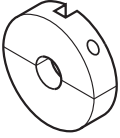
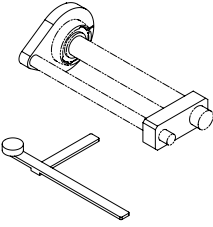
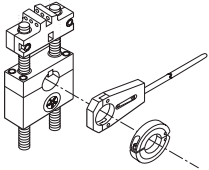
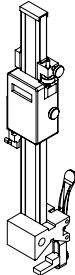
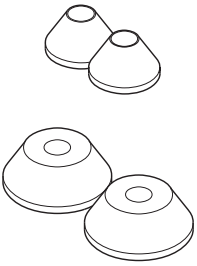

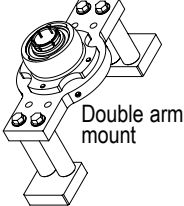
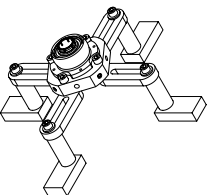
NOTE: Maximum recommended unsupported bar length (between bearing supports) is 18 inches (457.2 mm)

	NO. DESCRIPTION		NO. DESCRIPTION
	<p>Tool Head</p> <p>Tool heads can be positioned anywhere along the bar. Split body allows attachment without moving the bar. Included in Base Units shown on page 5.</p> <p>19449 Inch kit for 3.25 - 5 inch diameters.</p> <p>33713 Metric kit for 82.6 - 127 mm dia.</p> <p>Tool Kit (not shown) Complete set of tools for the boring machine, included in Base Units shown on page 5.</p> <p>19697 Inch kit</p> <p>37494 Metric kit</p>		<p>Automatic Bore Welding Accessories allow you to attach and quickly align the Climax AutoBoreWelders for efficient bore welding.</p> <p>26795 BoreWelder interface kit Allows you to attach and quickly align the Climax AutoBoreWelders for efficient bore welding. Includes adapter plate, alignment tool, and spherical bearing removal wrench.</p> <p>Bore Measuring Tool Features a fine adjustment feature which allows precision bore measurement and sets tool bit height while the bar is still mounted in the work piece.</p> <p>70645 Mounts on any bar from 1-¼ to 2-¼ inches (31.8 to 57.2 mm) in diameter. Measures up to 12 inches (304.8 mm) diameter bores.</p> <p>67487 Mounts on any bar from 1-¼ to 2-¼ inches (31.8 to 57.2 mm) in diameter. Measures up to 24 inches (609.6 mm) diameter bores.</p>
	<p>31412 Facing Head Assembly</p> <p>Face from 2 - 7 inches (50.8 - 177.8 mm) in diameter, or from 2 - 10 inches (50.8 - 254 mm) with leadscrew set. Bi-directional operation, 0.005 inch/rev (0.127 mm/rev) fixed feed rate.</p>		
	<p>Set-up Cones</p> <p>Aluminum set-up cones slide onto the bar and into bore holes for quick set-up.</p> <p>26263 Small set-up cone set, aluminum. For 1.5 to 3.25 inch (38.1 to 82.6 mm) diameter bores.</p> <p>26264 Large set-up cone set, aluminum. For 3.25 - 5 inch (82.6 - 127.0 mm) diameter bores.</p>		<p>Magnetic Back Dial Indicator Top quality travel dial indicator with magnetic back, made by Starrett® for Climax. Useful for many things including:</p> <ul style="list-style-type: none"> • Precisely setting depth of cut. • Measuring and setting boring bar travel when cutting to a shoulder. • Facing operations, precision alignment of boring bar to larger bores.
<p>Spherical mount</p>  <p>Double arm mount</p>  <p>Universal mount</p> 	<p>Bearing mounts</p> <p>Available in double arm and universal styles, our spherical bearing mounts attach directly to the work piece, and accept both the BB3000 rotational drive unit and the mounting bracket for the Climax AutoBoreWelders.</p> <p>26794 Spherical mount (required for all machines made before January, 1993)</p> <p>24756 Double arm mount</p> <p>36961 Universal mount</p> <p>37621 I.D. Mounting kit for universal mount</p>	 <p>Please note: Drawings are for reference only, are not to scale, and may not represent actual product.</p>	<p>45396 0 - .500 inch range (.001 increment) - white face</p> <p>45397 0 - 10 mm range (.01 mm increment) - yellow face</p> <p>Digital Bore Measuring Caliper Get an accurate reading of the bore without removing the bar. Features locking, micro-adjust slide.</p> <p>61707 Measures up to 10 inches (254.0 mm) ID/OD</p> <p>63330 Measures up to 24 inches (609.6 mm) ID/OD</p>

SETUP AND OPERATION

A Fast Six-Step Process

Setup of the BB3000 Portable Boring Machine is quick and easy. An experienced operator can set up the machine in most typical two-bore line boring applications in about half an hour (depending on alignment tolerances).

The three main ingredients of the quick setup system are:

- Setup cones to roughly center the bar in the bore.
- Spherical mounts that can be quickly tack-welded in place.
- Quick-mount rotational drive unit, attaches to spherical mount in seconds

1

Slide the bar through the two holes to be bored and roughly center it with the set-up cones. The set-up cones are forced into the bore with the clamp ring jacking screw and locked onto the bar with a set screw.

Elapsed time: 4 minutes.



4

Slide the rotational drive onto the bar until the self-aligning mounting collar is firmly seated on the mounting bracket, and lock it in place with one screw.

Elapsed time: 2 minutes.



2

Slide on spherical mounts with tack weld plates, and tack weld them to the workpiece.

These mounts have spherical bearings so they can be mounted up to 5° out of perpendicular alignment.

Elapsed time: 10 minutes.

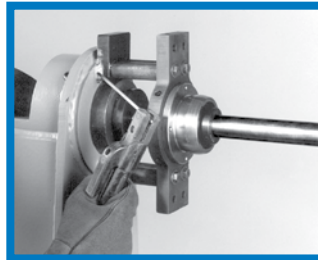

5

With the hand crank, place the rotational drive unit so you have enough stroke for your first boring pass. Tighten the rotational drive clamping collar firmly to lock the rotational drive to the bar.

Elapsed time: 2 minutes.

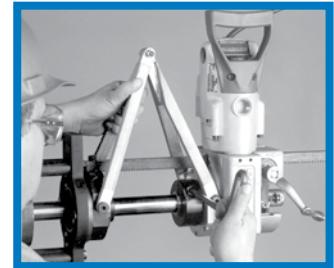

3

Remove the set-up cones and replace the bar. The set-up cones will adequately center the bar, unless you have very precise tolerances, or need to move the center line of the bore slightly. Final centering adjustments are made with the jacking screws.

Elapsed time: 5 minutes.

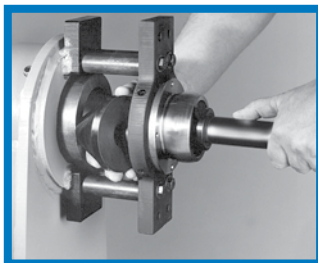

6

Insert a properly ground tool bit into the tool hole in the bar, adjust for depth of cut, and lock in place with the set screw.

Elapsed time: 4 minutes.

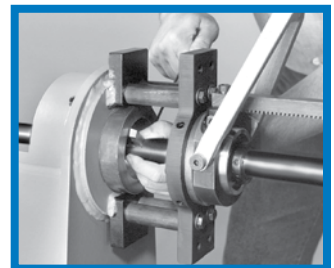

Setup is complete, you are ready to begin the first pass.

Total elapsed time: 27 minutes.

Training at the Global Learning Center

Climax has been teaching the fundamentals and fine points of portable machine tool operation for practically as long as we've been inventing and building the tools.

At the Climax Global Learning Center situated in our corporate headquarters near Portland, Oregon, we provide training for machine tool operators on portable machine tool safety, and machine setup and operation. Trainees also receive technical tips and tools to improve operational efficiencies, with the vast majority of every program devoted to hands-on activities and skill development.



The Climax instructional team includes specialists in shipbuilding, power generation, civil engineering, bridge re-building, petrochemical and other industries.

Whether it's a regularly scheduled course at the Global Learning Center, or custom curriculum conducted at your facility, your machinists will benefit from courses developed by some of the most respected authorities in the business.

Call us today to register for a regularly scheduled class, or talk to us about how we can customize a training program for your specialized application.



CLIMAX GLOBAL LOCATIONS



Call Climax for:

On-site Training



Need some refresher courses in setting up and operating your Climax machine tool?

Special Projects

Climax has been solving complicated on-site machining and welding problems for our customers since 1964.

Rentals

With 14 worldwide rental depot locations, you are never far away from a Climax portable machine tool.

Connect with us:  

World Headquarters

2712 E. Second Street
Newberg, Oregon 97132 USA
Worldwide Telephone: 1.503.538.2185
N. America Toll-Free: 1.800.333.8311
Fax: 1.503.538.7600
Email: info@cpmt.com

European Headquarters

Am Langen Graben 8
52353 Düren, Germany
Telephone: (+49) (0) 2421.9177.0
Fax: (+49) (0) 2421.9177.29
Email: info@cpmt.de