

Packing big boring capability into a compact, modular machine, maximizing efficiency and minimizing downtime.

Powerful Yet Compact

- Take the power of a stationary machine to the job site to solve tough machining challenges in record time.
- Using the 11.3 in³ (185.3 cm³) Hydraulic motor, it produces 1435 ft•lb (1945.6 N•m) of torque at the bar, at 33 rpm.
- Compact, modular components allow fast, easy setup, maximizing efficiencies, and minimizing downtime.

Versatile and Flexible

- Huge machining range bores from 8.8 - 38.0 inches (223.5 - 965.2 mm) in diameter, and faces from 7.5 - 42.1 inches (190.5 - 1069.3 mm) with various facing attachments.
- ID and End Mount Bearings feature spherical taper-lock roller bearings for easy setup and removal of the bar, and allow for up to 1.5 degrees of misalignment when setting up bearings.
- End mount bearings can be fine adjusted by +/- 0.625 inches (15.9 mm) to center the bar.
- Optional dual action boring/facing arms increase facing range, and allow for both boring and facing without switching equipment. Full-length square ways on boring/facing arms allow for quick positioning anywhere along the arm. Attaches to the net fit tool carrier by compression-clamping, to provide maximum tool stability.
- Net fit tool carrier can be clamped to bar for facing operations. For boring operations, carrier can be adjusted to remove clearance between carrier and the bar. This flexibility also ensures maximum rigidity for either operation.
- For even greater facing range and longer continuous stroke, the new boring/facing arms

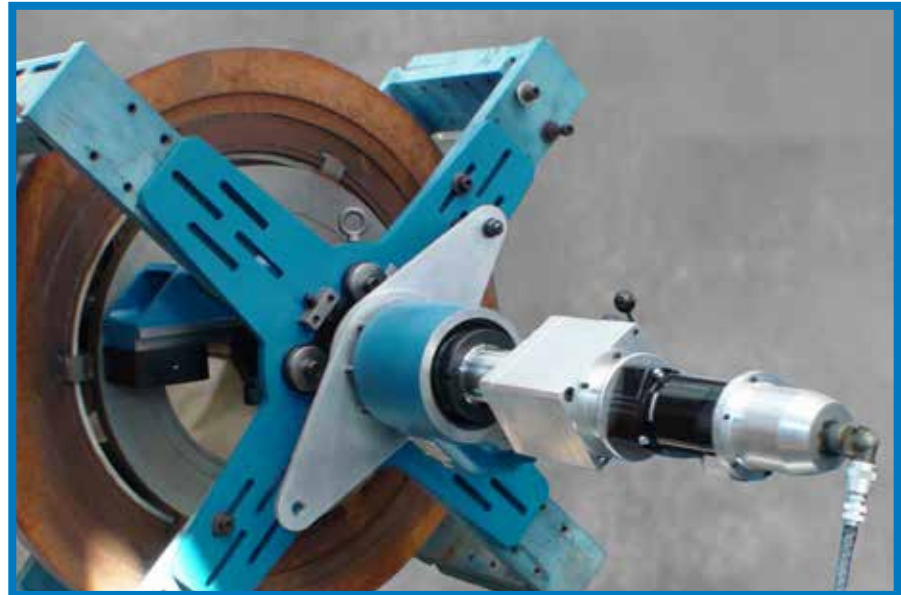

are available. Setup is quick & easy for both boring and facing operations.

- Net fit tool carrier is designed with a split frame to simplify installation on the boring bar. It can be configured to use either the boring head set for boring, the mechanical facing head for facing, or the new boring/facing arm assembly for both boring and facing operations.
- With leading & trailing boring head configuration, 2 boring heads can be used simultaneously.
- Highly versatile tool holder block accepts industry standard tooling with a nominal 3/4 inch (19.1 mm) square shank.
- Tool post on the boring/facing arm can be rotated to provide maximum flexibility in machining setup (including some cantilevered configurations).

High Quality Design

- Features a uniquely-designed modular tool carrier which provides a new level of strength and rigidity by channeling machining forces directly to the boring bar through strategically-located adjustable guide shoes.
- Durable chromed bars, straight to within 0.001 inch per foot (0.0254 per 304.8 mm) ensure accurate machining.
- Adjustable, removable half nut increases net fit tool carrier flexibility. Easy removal of tool carrier allows for machining of multiple bores.
- Backlash adjustment nut allows in-the-field adjustment to eliminate backlash in the tool carrier, and extend the life of the machine.

SPECIFICATIONS

	US	Metric
Boring and Facing Ranges:		
Boring diameter range, standard stack block assembly:	8.8 - 38.0 inches	223.5 - 965.2 mm
Boring diameter range, boring/facing arm assembly:		
with 18 inch (457.2 mm) boring/facing arm	19.9 - 32.1 inches	505.5 - 815.3 mm
with 23 inch (584.2 mm) boring/facing arm	24.8 - 42.1 inches	629.9 - 1069.3 mm
Recommended facing diameter range, using mechanical facing head assy:	10.6 - 38.0 inches	269.2 - 965.2 mm
Facing diameter range, boring/facing arm assembly:		
with 18 inch (457.2 mm) boring/facing arm	17.5 - 32.1 inches	444.5 - 815.3 mm
with 23 inch (584.2 mm) boring/facing arm	17.5 - 42.1 inches	444.5 - 1069.3 mm
Facing diameter range, boring/facing arm assembly, tool post reversed: ("tool post reversed" refers to rotating the tool post so that the tool is on the bar side of the tool post.)		
with 18 inch (457.2 mm) boring/facing arm	7.5 - 20.1 inches	190.5 - 510.5 mm
with 23 inch (584.2 mm) boring/facing arm	7.5 - 30.1 inches	190.5 - 765.5 mm
Performance Data		
Rotational Drive Unit (RDU) gear ratio:	6:1 gear reduction	6:1 gear reduction
Hydraulic motor size affects torque and speed Theoretical values calculated using a 10 Hp hydraulic power unit producing 2000 psi (13790 kPa) continuous, [normal operation is 1200 psi (8270 kPa)] and pumping 10 gpm (37.9 l/min).		
Hydraulic motor size range:	3.6 - 17.9 in ³	59.9 - 293.3 cm ³
Boring Bar Torque:	470 - 1820 ft•lb	637.2 - 2467.6 N•m
Max boring rpm:	107 - 21 rpm	107 - 21 rpm
For example, with 11.3 in ³ (185.3 cm ³) hydraulic motor (43457):		
Boring Bar Torque:	1435 ft•lb	1945.6 N•m
Max boring rpm:	33 rpm	33 rpm
Feed Rate of mechanical Axial Feed Unit (AFU):	0.003 - 0.020 inches/rev	0.076 - 0.508 mm/rev
Feed Rate of electric Axial Feed Unit (AFU):	0 - 0.3 inches/min	0 - 7.62 mm/min
Measures		
Shipping Weights (estimated): Machine includes Rotational Drive Unit (RDU), Axial Feed Unit (AFU), boring head set, tool carrier, tool kit, and hydraulic motor.		
for machine (wood crate)	640 lbs	290.3 kg
for machine (metal crate)	740 lbs	335.7 kg
for one 4 arm bearing assembly	160 lbs	72.6 kg
for one 3 arm bearing assembly	80 lbs	36.3 kg
for boring bar	2.5 lbs/inch	0.04 kg/mm
for 10 Hp Hydraulic Power Unit	500 lbs	226.8 kg
Shipping dimensions:		
Machine, in wood crate, W, D, H	18.5 x 34 x 24 inches	469.9 x 863.6 x 609.6 mm
Machine, in steel crate, W, D, H	43.3 x 29.5 x 22.5 inches	1099.8 x 749.3 x 571.5 mm
Bearing (each bearing shipped separately) W, D, H	32 x 32 x 11 inches	812.8 x 812.8 x 279.4 mm
12 foot (3657.6 mm) bar W, D, H	11 x 13 x 154 inches	279.4 x 330.2 x 3911.6 mm
10 Hp Hydraulic Power Unit W, D, H	27 x 33 x 48 inches	685.8 x 838.2 x 1219.2 mm

All dimensions should be considered reference. Contact your Climax Representative for precision dimensions. Specifications are subject to change without notice. There are no systems or components on this machine that are capable of producing hazardous EMC, UV or other radiation hazards. The machine does not use lasers nor does it create hazardous materials such as gasses or dust.

TOOL CONFIGURATIONS

Configure your BB6100 in eight easy steps.

To configure your BB6100 Boring Machine:

- 1 Select a Base Unit
- 2 Select an Axial Feed Assembly
- 3 Select Bearing Assemblies
- 4 Select a Boring Bar
- 5 Select a Boring Head Set
- 6 Select a Hydraulic Motor
- 7 Select a Facing Assembly
- 8 Select a Shipping Container

To configure the boring machine you require, simply select the option you need in each step, then contact your Climax representative.

1 Base Unit	
Rotational drive unit, net fit tool carrier assembly, tool kit, and instruction manual.	54398
2 Axial Feed Assembly	
Mechanical axial feed assembly	23299
Electrical axial feed with mechanical rapid return, 120V	43735
Electrical axial feed with mechanical rapid return, 230V	41071
3 Bearing Assemblies	
Spider assembly 3 arm end bearing support Mounting range: 12 - 20 inches (304.8 - 508.0 mm)	53840
Spider assembly 4 arm end bearing support Mounting range: 18 - 38 inches (457.2 - 965.2 mm)	53710
ID Bearing mount assembly, for ID diameters of 11.25 - 47 inches (285.8 - 1193.8 mm)	54355
* Multiple units may be ordered.	
4 Boring Bar (3.5 inch (88.9 mm) dia.)	
Boring bar assembly, 4 feet (121.9 cm)	25221
Boring bar assembly, 5 feet (152.4 cm)	22107
Boring bar assembly, 6 feet (182.9 cm)	22108
Boring bar assembly, 7 feet (213.4 cm)	22109
Boring bar assembly, 8 feet (243.8 cm)	22110
Boring bar assembly, 9 feet (274.3 cm)	22111
Boring bar assembly, 10 feet (304.8 cm)	22112
Boring bar assembly, 11 feet (335.28 cm)	22113
Boring bar assembly, 12 feet (365.76 cm)	22114
Boring bar assembly, 13 feet (396.24 cm)	22777
Boring bar assembly, 14 feet (426.72 cm)	22770
Boring bar assembly, 16 feet (487.68 cm)	22789
Boring bar assembly, 17 feet (518.16 cm)	30248
Boring bar assembly, 20 feet (609.6 cm)	36485
* Multiple units may be ordered.	
5 Boring Head Sets	
Boring head set, 8.8 - 26 inches (223.5 - 660.4 mm) tenthset with square tooling slot	54342
Boring head set, 8.8 - 38 inches (223.5 - 965.2 mm) tenthset with square tooling slot	54343
Boring head set, 8.8 - 26 inches (223.5 - 660.4 mm) tenthset with square tooling slot, leading and trailing	54344
Boring head set, 8.8 - 38 inches (223.5 - 965.2 mm) tenthset with square tooling slot, leading and trailing	54345
Boring head set, 11.5 - 26 inches (292.1 - 660.4 mm) solid tooling, leading and trailing	54346
Boring head set, 11.5 - 38 inches (292.1 - 965.2 mm) solid tooling, leading and trailing	54347

6 Hydraulic Motor Assembly	
Hydraulic motor assembly, 3.6 CIR (59 cm ³ /rev) 85.5 bar rpm @ 10 gpm (37.9 l/min)**	43438
Hydraulic motor assembly, 5.9 CIR (97 cm ³ /rev) 52 bar rpm @ 10 gpm (37.9 l/min)**	43439
Hydraulic motor assembly, 7.3 CIR (120 cm ³ /rev) 42 bar rpm @ 10 gpm (37.9 l/min)**	43440
Hydraulic motor assembly, 8.9 CIR (146 cm ³ /rev) 34 bar rpm @ 10 gpm (37.9 l/min)**	43441
Hydraulic motor assembly, 11.3 CIR (185 cm ³ /rev) 27 bar rpm @ 10 gpm (37.9 l/min)**	43442
Hydraulic motor assembly, 14.1 CIR (231 cm ³ /rev) 22 bar rpm @ 10 gpm (37.9 l/min)**	43443
Hydraulic motor assembly, 17.9 CIR (293 cm ³ /rev) 17 bar rpm @ 10 gpm (37.9 l/min)**	43444
* Multiple units may be ordered.	
** Theoretical, calculated values shown	
7 Boring/Facing Assemblies	
Mechanical facing head assy, 4 inch (101.6 mm)	22680
Mechanical facing head assy, 6 inch (152.4 mm)	49753
Mechanical facing head assy, 8 inch (203.2 mm)	49754
Boring/facing arm assembly, 18 inch (457.2 mm)	54385
Boring/facing arm assembly, 23 inch (584.2 mm)	54386
* Additional arms may be purchased separately.	
8 Shipping Container	
Plywood hinged crate, 24 x 37 x 20-5/8 (610 x 940 x 524 mm)	28560
Metal shipping container 43 x 30 x 23* (1092 x 762 x 584 mm)	54352
* Machine components only.	
Bars and bearings available in wood only.	

Further Customize your BB6100 with these options (order separately):

Small Bore Kit for 6 - 10 inch (152.4 - 254 mm) diameters	55198
Rotational Drive Unit	22221
Net Fit Tool Carrier	54224
Tool Kit	54262

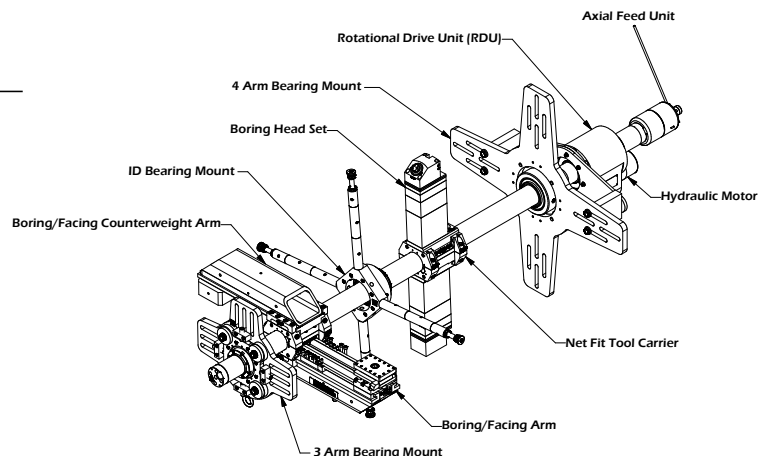

OPERATIONAL DIMENSIONS

Dimensions in Inch (mm)

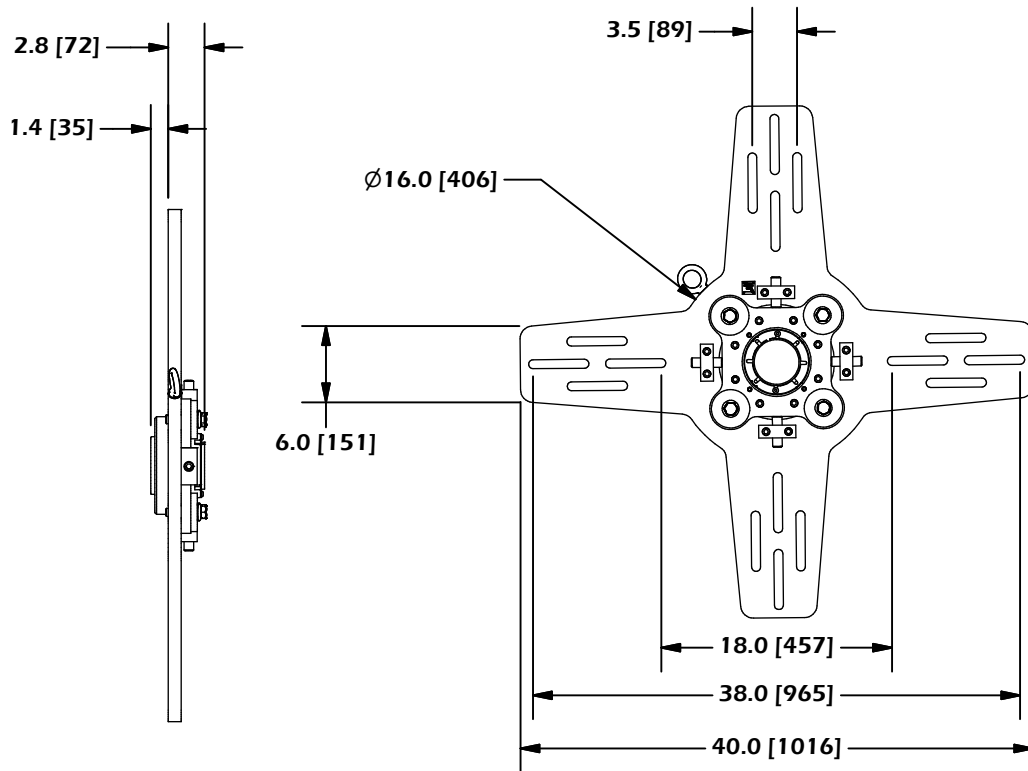

Spider Assembly 4-Arm End Bearing Support

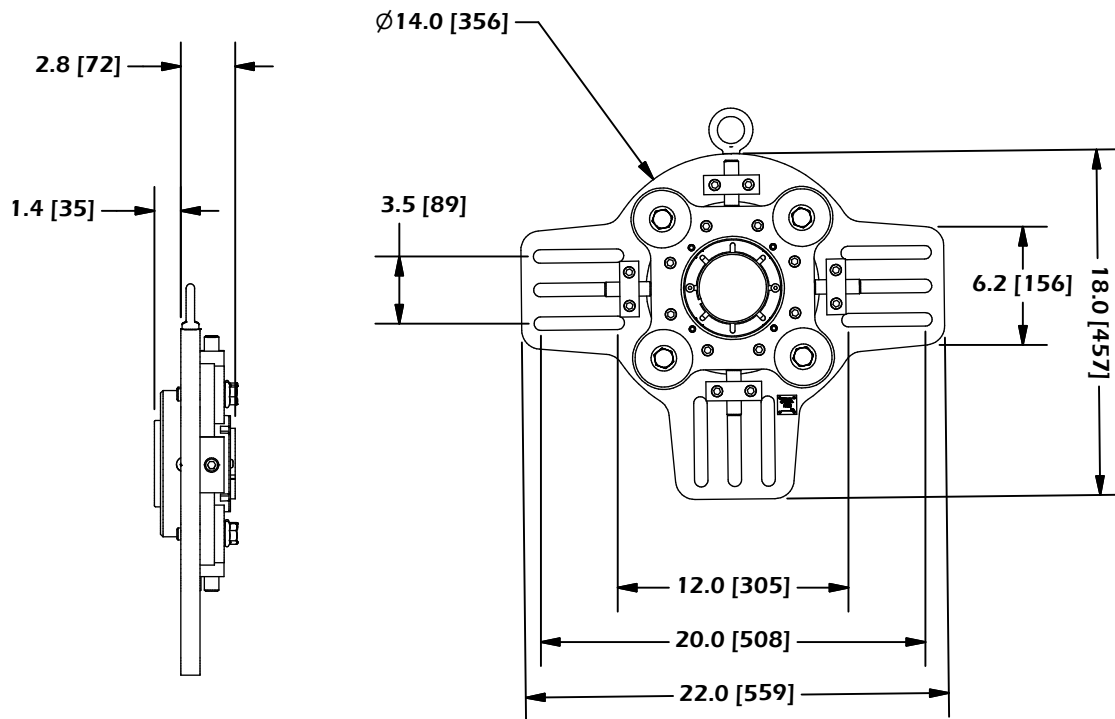

Spider Assembly 3-Arm End Bearing Support

OPERATIONAL DIMENSIONS

Dimensions in Inch (mm)

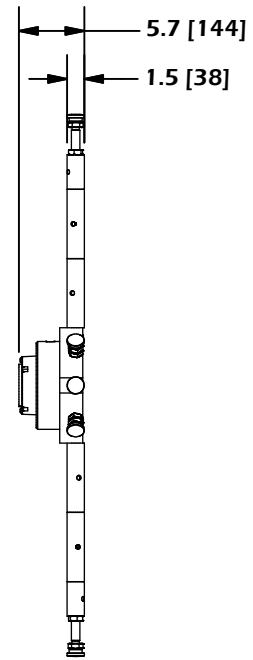
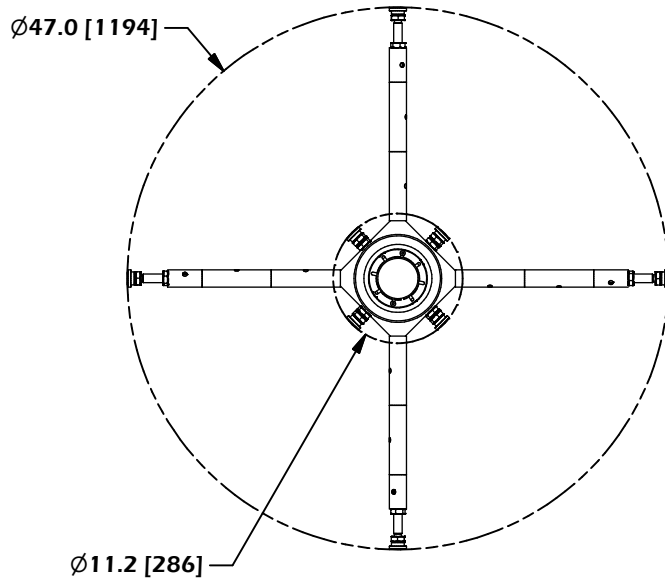

ID Bearing Mount Assembly
For ID diameters of 11.25 - 47 inches (285.8 - 1193.8 mm)

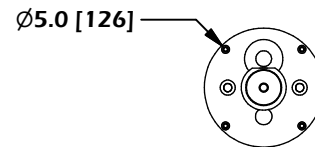
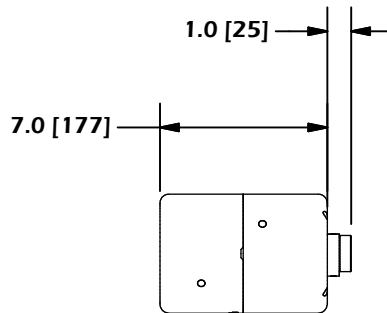

Mechanical Axial Feed Assembly

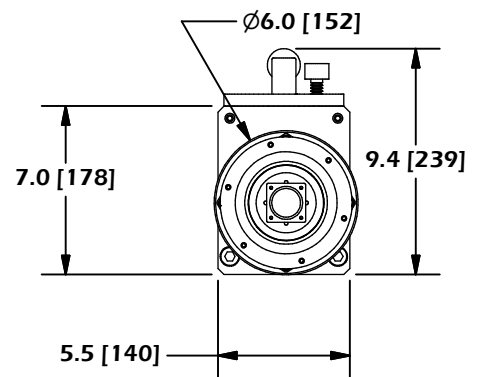
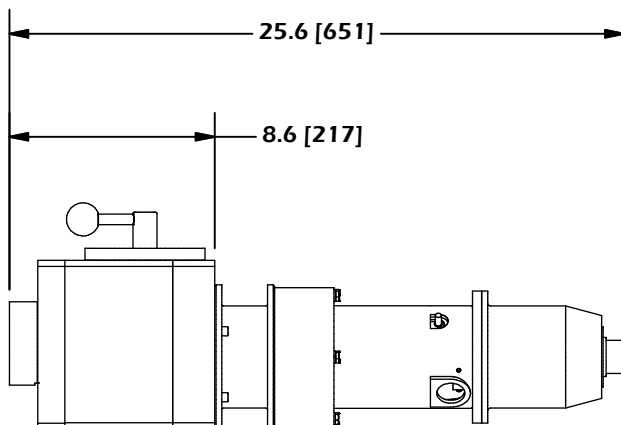

Electrical Axial Feed Assembly

OPERATIONAL DIMENSIONS

Dimensions in Inch (mm)

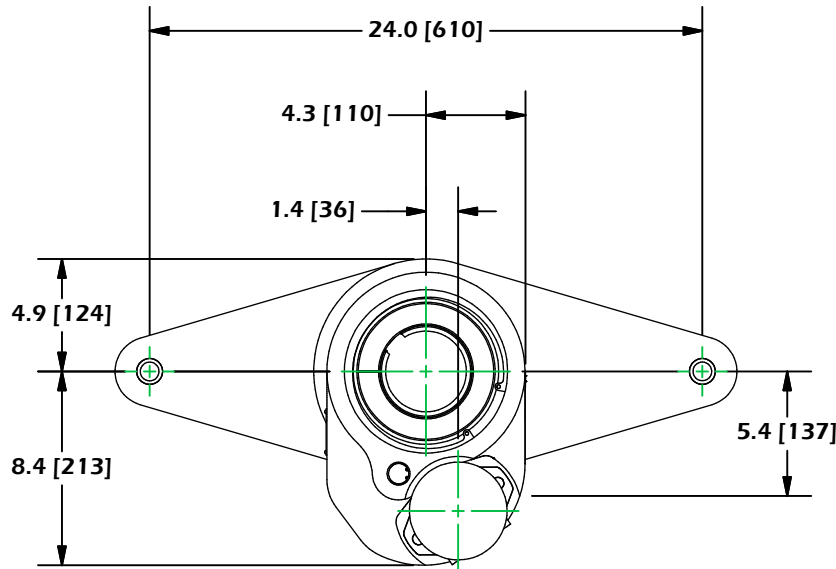

Rotational Drive Unit

MAX FACE/BORE
18" Ø32.1 [815]
23" Ø42.1 [1069]

MIN FACE
ALL ARM LENGTHS Ø17.5 [445]

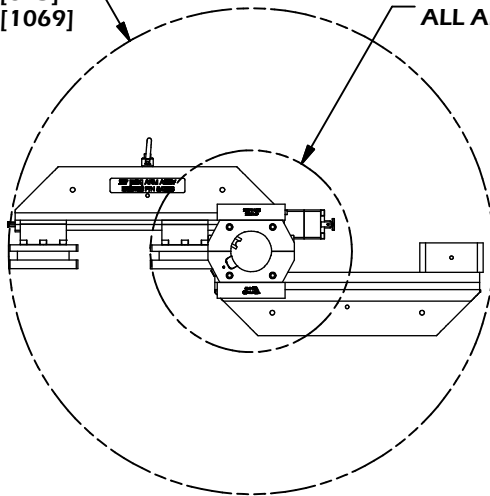

MIN BORE
18" Ø19.9 [506]
23" Ø24.8 [630]

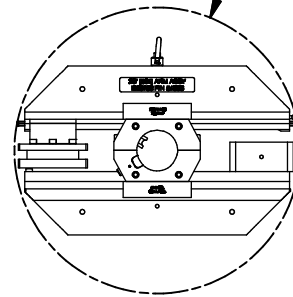

MAX FACE
TOOL POST REVERSED
18" Ø20.1 [511]
23" Ø30.1 [765]

MIN FACE
TOOL POST REVERSED
ALL ARM LENGTHS Ø7.5 [191]

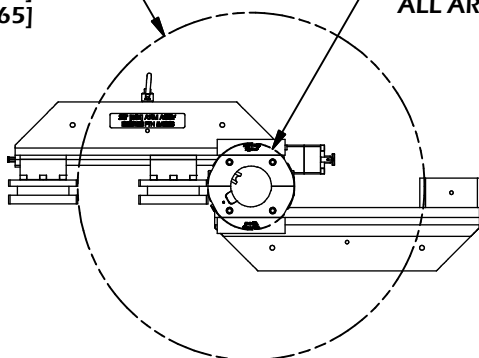

MIN FACE SWING
18" Ø24.0 [610]
23" Ø28.9 [735]

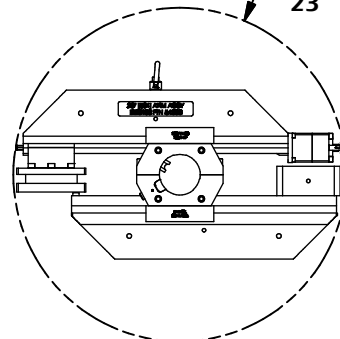

Boring/facing arm configurations

OPERATIONAL DIMENSIONS

Dimensions in Inch (mm)

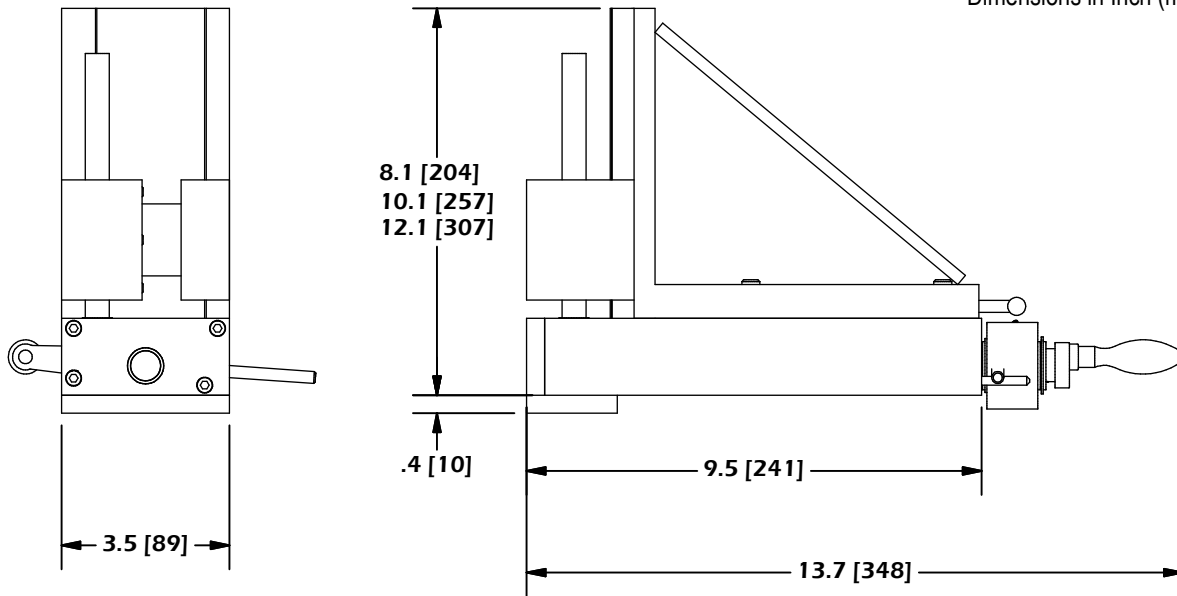

Mechanical Facing Assembly

Determining the Proper Bar Length for your BB6100

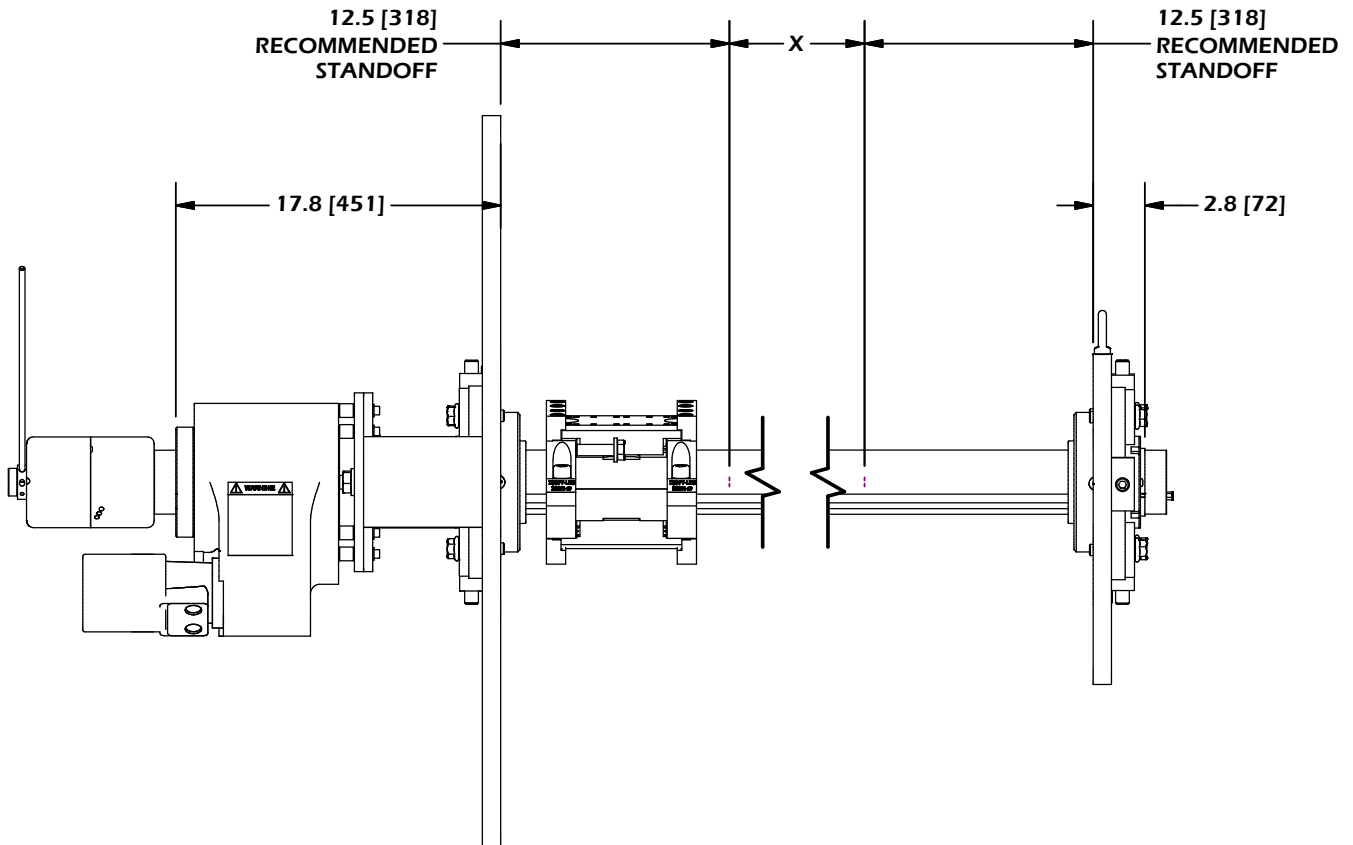

$$\text{BAR LENGTH} = X (\text{BORE LENGTH}) + 17.8 [451] + 2.8 [72] + \text{STANDOFF}$$

CLIMAX GLOBAL LOCATIONS



Call Climax for:

On-site Training

Need some refresher courses in setting up and operating your Climax machine tool?

Special Projects

Climax has been solving complicated on-site machining and welding problems for our customers since 1964.

Rentals

With 14 worldwide rental depot locations, you are never far away from a Climax portable machine tool.

Connect with us:  

World Headquarters

2712 E. Second Street
Newberg, Oregon 97132 USA
Worldwide Telephone: 1.503.538.2185
N. America Toll-Free: 1.800.333.8311
Fax: 1.503.538.7600
Email: info@cpmt.com

European Headquarters

Am Langen Graben 8
52353 Düren, Germany
Telephone: (+49) (0) 2421.9177.0
Fax: (+49) (0) 2421.9177.29
Email: info@cpmt.de

Copyright © 2013 Climax Portable Machining & Welding Systems. All Rights Reserved. Climax has taken reasonable measures to ensure the accuracy of the information contained in this document. However, Climax makes no warranties or representations with respect to the information contained herein; and Climax shall not be held liable for damages resulting from any errors or omissions herein, or from the use of the information contained in this document.

 **CLIMAX**
Portable Machining & Welding Systems