

HX 12P, HX 25P

NEW

Enclosed orbital weld heads

Welding stainless-steel pipes economically and with high quality using the TIG welding procedure: Unique in the entire world, HX orbital weld heads are the best solution for efficient, high-quality production thanks to their automated welding technology. Pre-mounted pipe elbows (for example in heat exchanger construction), even those in tight pipe bundles, can be joined to small stainless-steel pipes reliably, quickly and safely.



In addition to the HX 12P and HX 25P, this series also includes the HX 16P.

When done by hand, the welding of pipe elbows for heat exchanger construction is an exhausting task. In addition, consistently high quality (and thus the proper sealing of all pipe elbows) on a continual basis by the welder can't be guaranteed. This results in expensive correction work and lots of waste.

While conventional heads and tongs require lots of space between the pipes for positioning, slim HX heads make it possible to build very compact heat exchangers with a high pipe density and thus a high degree of efficiency. Pipe spacings under 40 mm (1.57") are possible with the HX 12P and under 60 mm (2.36") with the HX 25P.

Handling is easy, too. HX heads are opened up, placed around a pipe and clamp themselves pneumatically at the push of a button. A stop with coarse and fine adjustment aids secure

positioning on the pipe. Following the startup procedure, the water-cooled head floods with argon gas and welding is carried out automatically with consistently high quality. The Orbitalum system ensures clean weld penetration with no recesses, gaps or burrs in the pipe whatsoever. Clamping and starting are activated by pressing buttons on the weld head.

Top-quality welding results, even with semi-skilled personnel

Orbitalum welding power supplies automatically detect the connected HX head and its specified parameters in such a way that the operator need only call up the corresponding welding procedure and initiate the process prior to the start of welding. Working with the Orbitalum system is so easy and reliable that even semi-skilled operators can achieve optimum welding results.

Practice has shown that waste can be reduced from 4% to under 0.7% with the Orbitalum

system. Another advantage of the system is that an operator can work with multiple weld heads at the same time, which increases production efficiency considerably. The closed welding chamber and consistent process also prevent annealing coloration from occurring, so expensive reworking such as pickling and passivation can usually be dispensed with.

Compact design makes handling easy

In contrast to open welding tongs, all connections for power, gas and cooling water are integrated into the HX head. To facilitate handling, Orbitalum heads are connected to the welding power source with a flexible 7.5 m hose. The HX 12P and HX 25P also scores with its straight design, which enables easy turning of the head at the heat exchanger. The entire unit can be suspended from a balancer to take the strain off the operator.

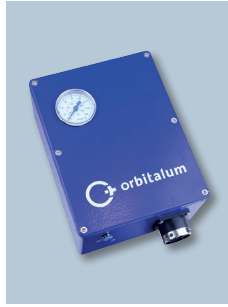

Extremely narrow design - ideal for the welding of pre-mounted elbows in tight pipe bundles

Pneumatic box included in the scope of delivery

Available option: Diameter-specific clamping inserts

Available option: Earth cable

Available option: Adjustable bar pressure regulator for Argon

The perfect complement: Orbital welding power supplies ORBITAT

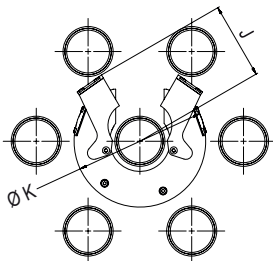
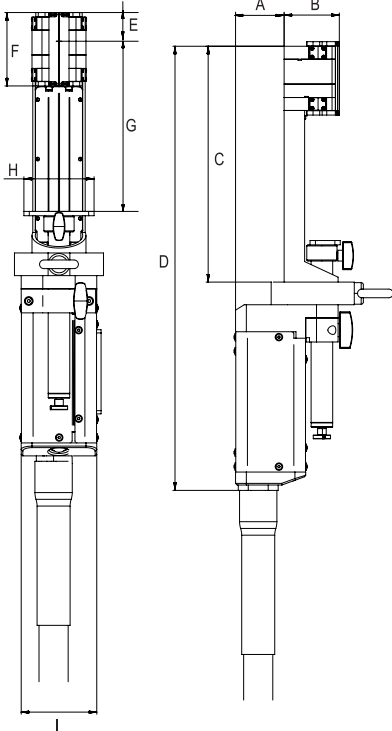

APPLICATION RANGE	HX 12P	HX 25P		
Code	847 000 010	845 000 010		
Tube OD, min. - max.*	9.5 - 13.3 mm / 0.374" - 0.524"	18.0 - 25.4 mm / 0.708" - 1.000"		
Wall thickness, min. - max.	0.5 - 0.8 mm / 0.02" - 0.03"	0.5 - 1.0 mm / 0.016" - 0.039"		
TECHNICAL DATA	HX 12P	HX 25P		
Electrode Ø	1.6 mm / 0.063"	1.6 mm / 0.063"		
Machine weight including hose package	6.4 kg / 14.1 lbs	18.5 kg / 40.8 lbs		
Hose package length	7.5 m / 24.6 ft	7.5 m / 24.6 ft		
TECHNICAL DATA	PNEUMATIC BOX	PNEUMATIC BOX		
Input	Argon	Argon		
Recommended input pressure	6 bar / 87 PSI	6 bar / 87 PSI		
DIMENSIONS	HX 12P	HX 25P		
	[mm]	[inch]	[mm]	[inch]
Dimension "A"	45.0	1.772	62.0	2.441
Dimension "B"	52.0	2.047	68.0	2.677
Dimension "C"	219.0	8.622	278.0	10.945
Dimension "D"	412.0	16.220	496.0	19.528
Dimension "E" (Electrode), min.	30.0	1.181	35.0	1.378
Dimension "F"	70.0	2.756	80.0	3.150
Dimension "G" up to max.	155.0	7.283	210.0	8.268
Dimension "H"	65.0	2.559	80.0	3.150
Dimension "I"	70.0	2.756	100.0	3.937
Dimension "J" (Ø)	33.0	1.299	43.0	1.693
Dimension "K"	50.0	1.969	72.0	2.835
SCOPE OF DELIVERY	HX 12P	HX 25P		
Enclosed orbital weld head of the HX series	Pc. 1	1		
Durable storage and shipping case	Pc. 1	1		
Pneumatic box	Pc. 1	1		
Supply hose (2 m/6.56 ft) for pneumatic box	Pc. 1	1		
Pivoting arm	Pair 1	1		
Elbow stop	Pc. 1	1		
Tool set	Set 1	1		
Power connector adapter	Pc. 1	1		
Operating instructions and spare parts list	Set 1	1		
SUITABLE ACCESSORIES	Available option: <ul style="list-style-type: none"> • Clamping inserts • Bar pressure regulator Argon • Earth cable • WS2 tungsten electrodes • ESG tungsten grinders 			

The technical data are not binding. They are not warranted characteristics and are subject to change.

* Other dimensions on request

