

ORBIWELD 19

Micro weld head
with additional advantages

Micro weld head

Small, robust and efficient: The OW 19 is the perfect tool when the task involves connections of ultra-high-purity tubes and high-performance tubes, such as are used for example in the semiconductor industry or applications in branches in which high purity and maximum performance are imperative. Even under extremely difficult conditions and in tight spaces the OW 19 produces excellent and reliable quality!

Can be used in all positions, irrespective of whether the tubes to be connected are positioned horizontally, vertically or inclined



Three-part clamping mechanism - no parts project beyond the head outline even in the opened position

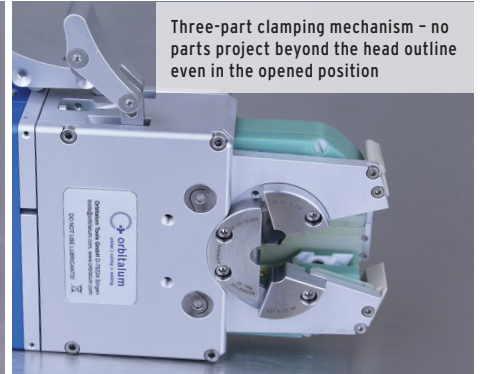

Outstanding range of applications - particularly in the semiconductor industry, aerospace technology, pharmaceuticals and supply of high-purity water

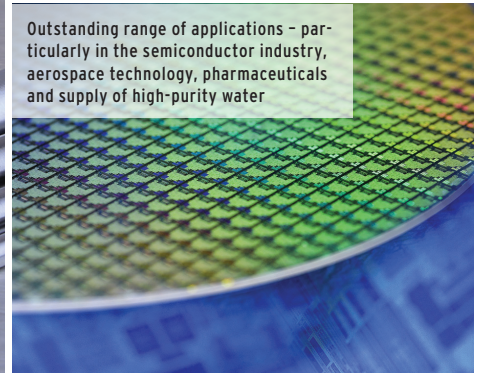

Its extremely high endurance thanks to the intensive liquid cooling as well as its high-quality robust construction are characteristics which distinguish this micro weld head.

The 3-part clamping mechanism ensures that the head can be clamped in the most confined spaces, as even when open no parts protrude beyond the contour of the head. Equally, an exact alignment, with no misalignment is guaranteed with the parts to be welded.

All the important commands for welding can be transmitted to the power supply via a control panel built into the robust and durable aluminum handle, so that no additional remote control is required.

All orbital welding power sources from Orbitalum automatically detect the head and its properties so that the operator only has to call up his or her specified jointing program and start the joining process before beginning to weld.

The matching clamping inserts are available in narrow and broad versions and can be inserted into the weld head with just a few simple steps.

The head is 7.5 kg (16.5 lbs) light. All connections for electricity, gas, cooling water are firmly integrated in the OW 19.

To increase productivity, the optional ORBITWIN switching unit allows working with up to two heads in an alternating fashion, thus reducing conversion times and downtimes considerably.

Including highly flexible hose package (length: 7.5 m/24.6 ft) with strain relief to the power source - optionally extendable to up to 20.0 m (64 ft).

The OW 19 - with many additional advantages:

- ✓ Optimized scissors clamping system
- ✓ Flip-up weld head cover "FlipCover"
- ✓ Optimized weld gas control
- ✓ One-hand operation
- ✓ Completely liquid-cooled
- ✓ Integrated control panel
- ✓ 7.5 m (24.6 ft) hose package



Robust and stable aluminum handle with integrated control panel

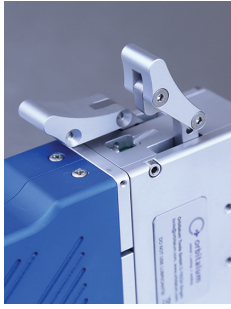

Practical clamping locks allowing single-hand operation

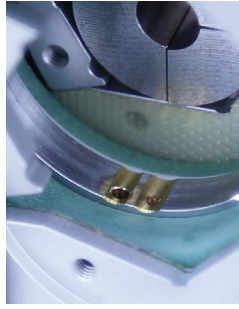

Simpler inserting of the electrodes by markings for $\varnothing 1.0/1.6$ mm (0.039"/0.063")

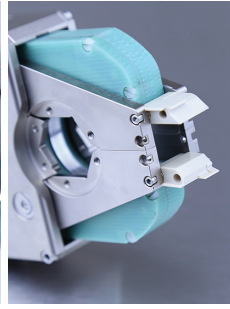

Flip-up weld head cover "FlipCover"



Diameter-specific clamping inserts (each 6-parts, wide and narrow) available separately



Comprehensive range of accessories, e.g. ORBIPURGE forming set

APPLICATION RANGE	ORBIWELD 19
Code	822 000 010
Tube OD, min. - max.	3.0 - 19.05 mm 0.118" - 0.750"
Electrode \varnothing	1.0 / 1.6 mm 0.039" / 0.063"
Machine weight including hose package	6.5 kg 14.3 lbs
Hose package length	7.5 m 24.6 ft

SCOPE OF DELIVERY	
Including:	<ul style="list-style-type: none"> • 1 Micro weld head ORBIWELD 19 • 1 Durable storage and shipping case • 1 Tool set • 1 Power connector adapter • 1 Feeler gauge • 1 Operating instructions and spare parts list
Suitable accessories (available option):	<ul style="list-style-type: none"> • Clamping inserts for OW 19 • ESG tungsten grinders • ORBmax residual oxygen meter • ORBIPURGE forming set • Hose package extensions • WS2 tungsten electrodes

ORBIWELD 19	DIMENSION		ELECTRODE INTERVAL			
	[MM]	[INCH]	CLAMPING INSERT TYPE "S"		CLAMPING INSERT TYPE "W"	
Dimension "A1"	12.00	0.472	12.00	0.472		
Dimension "A2"	17.00	0.669			17.00	0.669
Dimension "B1"	24.00	0.945	24.00	0.945		
Dimension "B2"	34.00	1.339			34.00	1.339
Dimension "C"	66.50	2.618				
Dimension "D"	33.25	1.309				
Dimension "E"	35.20	1.386				
Dimension "F"	44.50	1.752				
Dimension "G"	313.50	12.343				
Dimension "H"	76.00	2.992				
Dimension "I"	34.00	1.339				
Dimension "J"	35.00	1.378				
Dimension "K"	71.00	2.795				

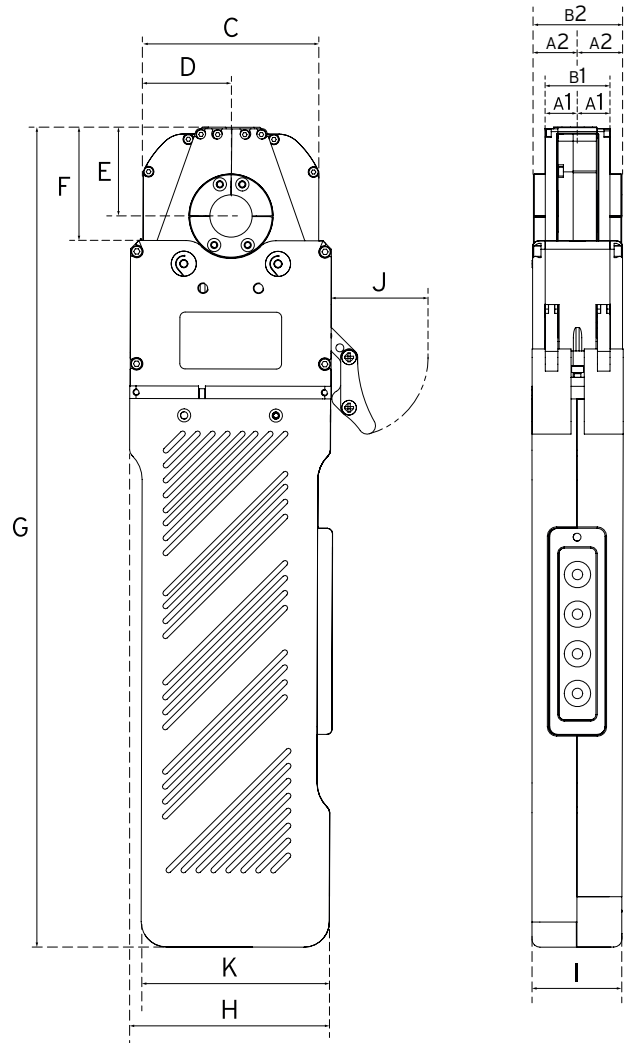

The technical data are not binding. They are not warranted characteristics and are subject to change.

