

# CP150-250

CRANKSHAFT STRAIGHTENING PRESS

AZ spa engine rebuilding / CRANKSHAFT



# CP150-250 / Crankshaft Straightening Press

## SPECIFICATIONS

		CP150	CP250
Table length	mm	1900	2800
Max distance between support	mm	1600	2500
Height of spindle axis from table	mm	215	215
Max journal diameter	mm	110	150
Max force	kg	8000	8000

## STANDARD EQUIPMENT

- 1 blunt center
- 2 conic centers
- Crankshaft centering device with dial indicator
- Pump with manometer
- Service tools
- Operating manual



Blunt center



Pump with manometer



Conic center



Crankshaft Centering device

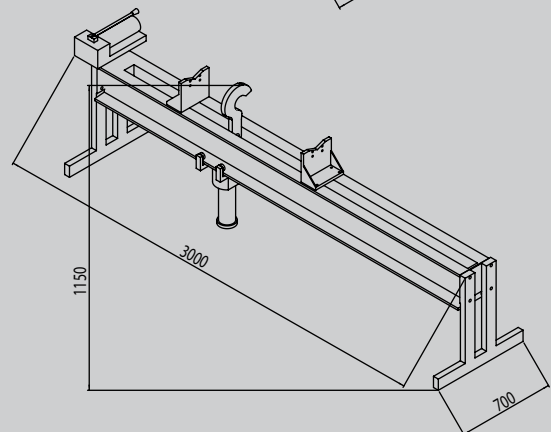
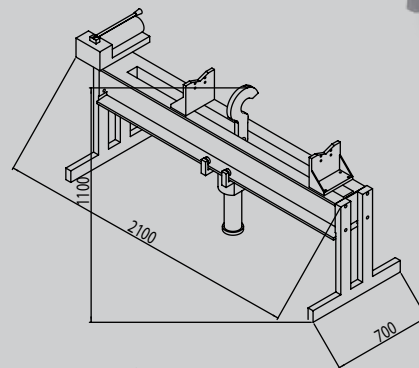

Fast and easy to use, CP150-250 saves time during grinding operations. The crankshaft is placed on the "V" supports adjustable in length and, through a special hook, fitted on a mobile hydraulic cylinder. You apply the desired pressure through a manual pump. Through the centesimal dial gauge, you can control the size of the crankshaft offset



**AZ spa**

Viale dell'Elettronica, 20  
36016 THIENE VICENZA ITALY

T +39(0)445575543

F +39(0)445575756 / +39(0)445575640

E info@azspa.it

[www.azspa.it](http://www.azspa.it)