

ROTTLER

THE CUTTING EDGE

F100 Series **Multi-Purpose CNC** **Machining Centers**

Now with
DIRECT
DRIVE
Ball Screws!

*Main Line Boring
Waukesha 7042*



*Surfacing
CAT C175-V20*



Machine Tools for the Performance Racing, Engine Remanufacturing and OEM Manufacturing Industries

F100A MULTI-PURPOSE CNC MACHINING CENTER

The F100 machines employ an entire array of features which help maximize the productivity capabilities of the machines. Quick tooling change-over maximizes the versatility and flexibility of the machine, allowing boring and surfacing in one set-up. All F100 Series machines have the capability of Boring, Surfacing, Line Boring, and Universal Machining. Traveling column and spindle movements are operated by precision ball screws and AC servo motors. Optional Automatic cycle software and production tooling allow complete block banks to be machined without operator attendance, once the job is set up and the "cycle start" button is pressed, the operator is free to "walk away" and do other work while the F100 completes a block bank or main line bore unattended!

Large Diameter Spindle

All F100 machines incorporate the use of a large diameter hard chromed spindle, utilizing high precision angular contact bearings and automatic lubrication.

Sliding Quill Spindle Design

Starting in 1923 Rottler pioneered the sliding quill spindle design that has proven to give decades of precision and reliable machining. Over the last 90 years, Rottler has perfected this design which is ideal for deep hole machining such as engine block machining. Resleeving long cylinders and machining lower seal area are examples requiring this unique feature. The spindle is hard chromed and cross hatch external honed then mounted in precision adjustable outer support bearings.

Work Head Box Way Slideway

Vertical machining requires rigid slideways for chatter free machining. Rottler exclusive spring loaded box way slideway design allows maximum rigidity and work head tilt for back clearance during surfacing operations.

Large Turite Coated Box Ways

Machine ways are induction hardened and coated with turcite low friction material and supplied with air pressure to reduce friction and give long service life.

Rapid Rate Speeds

Anti-friction **DIRECT DRIVE** ball screws and High Torque AC Servo motors provide precise machine positioning and rapid feed rates.

Air Power Drawbar

Air power drawbar allows cutterheads to be changed in seconds, increasing productivity and reducing operator fatigue. The machine can be changed from boring to surfacing in less than 15 seconds!

Instant Internet Support

Rottler offers cutting edge internet support direct from your machine to the factory. Skype™ and a webcam are installed for video conferencing and internet support. This feature gives you instant, direct contact with Rottler right on the machine without even making a phone call. The standard webcam comes pre-installed so that Rottler technicians can see exactly what you are seeing. This saves a tremendous amount of time when trying to answer questions and allows the end user to maximize the capabilities and productivity of the machine. Shop busy or too noisy for talking? The pre-installed Skype™ application gives you instant messaging capabilities with Rottler technicians.

Superior Surface Finish - No Back Cut

Automated work head tilting system for surfacing provides "back clearance" for superior surface finish.

Increased Clearance

Increased clearance from spindle centerline to the machine's column allow large castings to be set up and machined.

Extra-Long T-Slot Work Table

Extra-long work table offers enough space for dual workstations increasing productivity and versatility.



DUAL WORKSTATIONS
Line Boring a CAT3406E Cylinder
Head and Boring/Surfacing a
Mercedes 4000 Block

Windows Operating System

Rottler uses Windows Touch Screen Technology. The Windows software has many advantages such as it's common user interface and reduced learning curve. The machine can be operated in any language simplifying training in international countries.

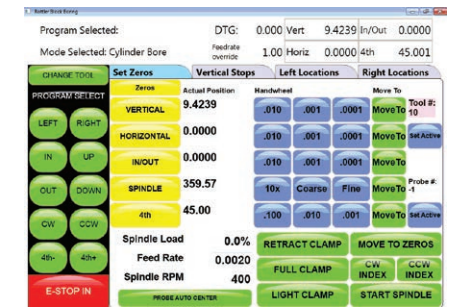

Manual Hand Wheel

Offers the operator infinite control of machine movement in all axes for quick easy setup and adjusts variable feedrate when in automatic cycle.

Productivity

Up to 75% time savings over traditional machines.

Control

Touch Screen Controls located on one panel for ease of operation.

Automation

Automatically machines precise dimensions.

Flexibility

Block boring and surfacing, head surfacing, line boring, and general CNC machining.

Versatility

Change cutterheads from surfacing to boring and back in 15 seconds.

Heavy Duty

Rottler rugged machine tool quality for accuracy and long life – heat treated mehanite cast iron castings.

Automatic Lubrication System

Provides years of trouble free use and reduced wear.

AC Brushless Servo Motors with BISS Encoders

The F79A has the latest technology AC servo motors with BISS encoders offering 100 times finer resolution compared to previous models. These new AC servo motors give maximum torque and performance throughout the RPM range for improved accuracy and increased productivity.

DIRECT DRIVE Precision Ball Screws

New design with increased diameter **DIRECT DRIVE** Precision Ball Screws that eliminate backlash relating to belts and gearboxes given accurate and repeatable positioning and long trouble-free life.

BIG MACHINES

In both the size of the engines and scope of the market, "heavy-duty" has taken on a new and more important role on the world's stage. Around the globe, businesses depend on heavy-duty equipment for transportation, construction, mining and innumerable other functions. Though they operate in some of the most severe conditions imaginable, they are quite efficient. Contrarily, when they are out of service, they are extremely costly. Rottler's commitment to this arena has earned a reputation among OEM remanufacturers and large engine rebuilders worldwide. Our rugged equipment and unmatched versatility make Rottler the number one choice for heavy duty engine work. Rottler's Programmable Automatic Control makes these machines fast and accurate. The machines work like advanced CNC machining centers but Rottler's conversational programming technology makes them very easy to operate. No programming knowledge is required and operators are trained by factory technicians in just a few days to run these machines at full speed. The machines can be run manually and many unique jobs such as large connecting rods, gear housings and other often overlooked jobs can be performed with this versatile equipment.

F105

Table Size: 33x135" (850x3430mm)
 Horizontal Travel (X Axis): 132" (3350mm)
 In/Out Travel (Y Axis): 16" (406mm)
 Vertical Travel (Z Axis): 29" (736mm)

The massive F105A is designed for machining large engines used in the earthmoving, mining, oil and gas, power generation and marine work boat industries up to the size of V20 engines blocks such as the CAT3520 and C175 V20, MTU 4000 V20, Cummins QSK78, Waukesha 9390, and others.

*Main Line Boring
 a Waukesha 7042.
 Pictured with optional
 tool changer.*



F104

Table Size: 33x111" (850x2820mm)
 Horizontal Travel (X Axis): 108" (2750mm)
 In/Out Travel (Y Axis): 16" (406mm)
 Vertical Travel (Z Axis): 29" (736mm)

The F104A is designed for machining large engines used in the earthmoving, mining, oil and gas, power generation and marine work boat industries up to the size of the CAT3516 and 399, Cummins QSK 60, MTU 4000 V16, Waukesha 7042, and others.



*Machining Water Holes
 on the Head Gasket
 Face of a CAT3516
 Engine Block*

F103

Table Size: 33x83" (850x2100mm)
 Horizontal Travel (X Axis): 80" (2000mm)
 In/Out Travel (Y Axis): 16" (406mm)
 Vertical Travel (Z Axis): 29" (736mm)

*F103A Surfacing a
 CAT3508 Block*



The **F103A** is designed for machining smaller engine blocks used in 'On Highway' applications such as trucks and buses. At the same time it is a large machine capable of machining mid-range size blocks up to the size of a CAT3508 and 3412, Komatsu 170 V12, MTU 2000 V16, Cummins K38, Detroit 60, Mercedes 400 V12, and similar.

Automatic Boring Cycles

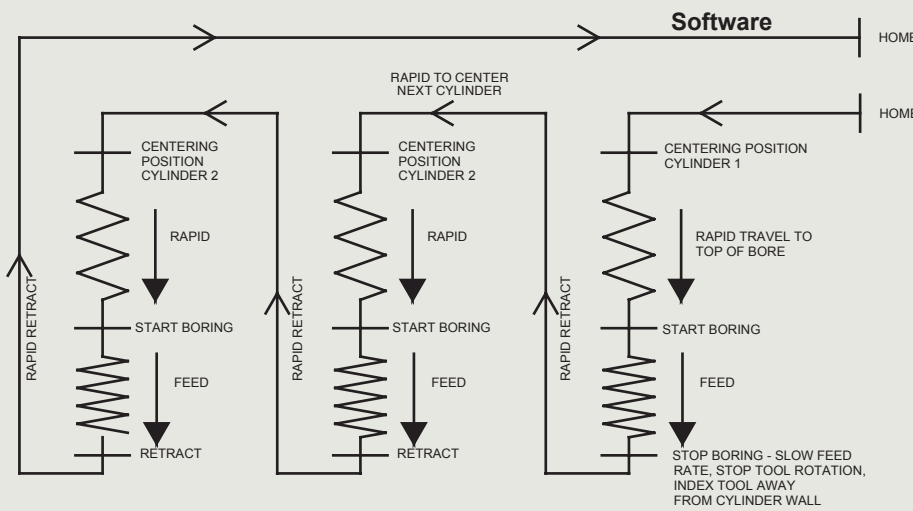

Over 20 years ago, Rottler pioneered automation by utilizing electronics and computers. Today, Rottler utilize the latest computer technology to make automation easy to learn, versatile to operate and upgradeable for future software. Windows operating system and touch screen control make a simple operator interface. Touch screen control allows ONLY the buttons and information required for each operation to be displayed, 'hiding' the complex computer functions in the background. Operators are able to learn complex and advanced machining functions in just a few days.

Common, everyday jobs such as boring, surfacing and line boring can be easily automated with the F100 machines. Operator attendance is only required for set up. The machine is capable of boring along a complete cylinder bank automatically. Likewise, the machine is capable of line boring along a main line automatically.

Often when surfacing a block, more than one pass is required. The F100 can be programmed for multiple passes, moving down the exact amount each pass and completing with a finish cut for the required surface finish during the final pass.

Bore centers are either measured from the block or from a blueprint, then saved in the memory. The F100 machine moves automatically to the exact positions, useful when multiple boring operations are required for jobs such as resleeving. For special applications, Optional Renishaw Wireless Probing can automatically find bore centers and measure diameters.

When resleeving the lower seal area of wet liner blocks, it is often required to bore a diameter larger than the upper diameter. Rottler's Automatic Lower Sleeve Repair Software allows the machine to offset so that the boring tool will clear the upper diameter, move down, then move back on center to bore the lower area on center with the upper bore. Once boring is complete, the machine will index the cutting tool, offset the programmed amount and retract and continue to the next cylinder – automatically.

Automatic Lower Sleeve Repair Software

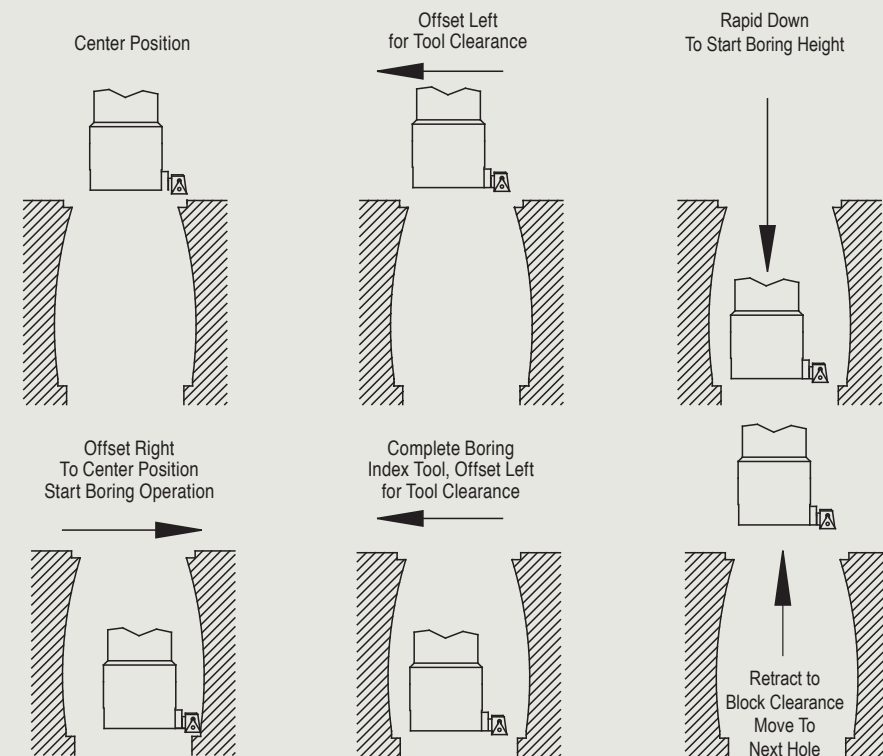

PRODUCTIVITY

Jobs can be completed in one third the time of conventional machines while operators can also do other work while the F100 completes automatic cycles unattended.

Rottler has combined our own in house CNC programming and machining experience with software and programming experts to develop a new conversational programming system that is easy to learn and operate. The use of Windows style icons and graphical displays makes programs easier to understand, the old fashioned abstract G&M code programming has been replaced with easy to understand conversational icons and menus. The use of Windows information allows easy handling - everyone knows about file saving and copying to external laptops and desktop computers. Programs can be emailed worldwide via the Internet and transferred by simple USB flash memory drives.

ROTTLER CAM (Computer Aided Manufacturing)

While the operator is developing a program on the machine, laptop or desktop, the software is calculating things like tool paths in the background. The software is able to convert a drawing into a complex CNC program and run the machine with very little operator involvement.

Water Hole Repairs

Large engine blocks and castings require many different repair and machining processes. The full 3 axis CNC control of the F100 series gives the machine the capabilities to perform custom programs to be written on the touch screen and saved in the memory for future use. For example, CAT3500 blocks have water holes in the head gasket face and often rust/corrode as a result of acidic water and require to be milled out, plugs fitted and the head gasket face to be surfaced. The F100 allows a simple CNC program to be written and these holes to be machined out in one automatic cycle. Plugs can then be fitted and the block surfaced. This can be done while the block is set up for boring and surfacing work, saving hours of time and improving accuracy.

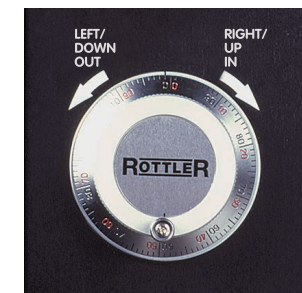

Hand wheel for Manual Movement and Variable Feedrate

The electronic hand wheel of the F100 machines has many uses. For manual movement, the operator is able to move the machine by rotating the hand wheel just like a manual machine. The hand wheel has a clicking action and each click moves the machine an exact amount: In Coarse Mode, the machine moves .010" (0.25mm) per click allowing very fast movement. In Medium Mode, the machine moves .001" (0.025mm) per click allowing slower movement. In Fine Mode, the machine moves .0001" (0.002mm) per click allowing very fine movement of the machine.

Once the machine is operating in automatic cycle, the operator is able to vary the feedrate or speed of movement from zero to 100%. This allows operators to slow down and speed up automatic movement while not changing the spindle/cutting speed. This function is ideal for operators learning the machine and checking their programs to be sure they have best productivity and safety, and not damaging cutting tools and jobs.

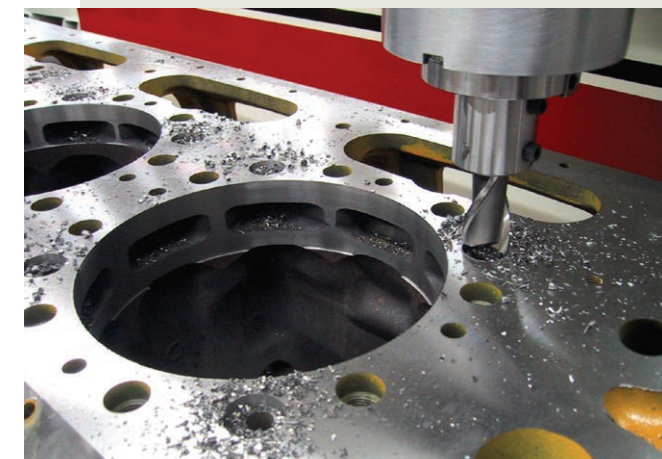
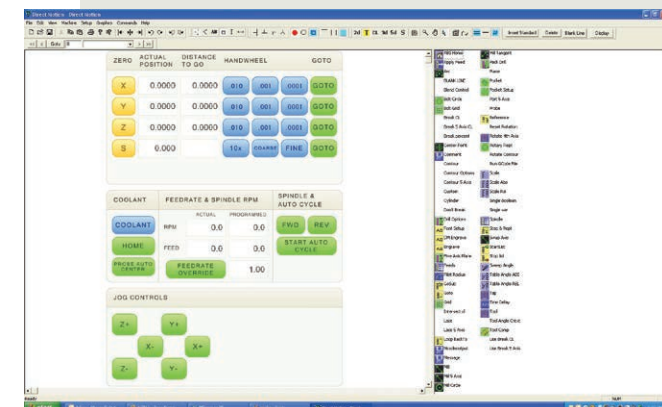
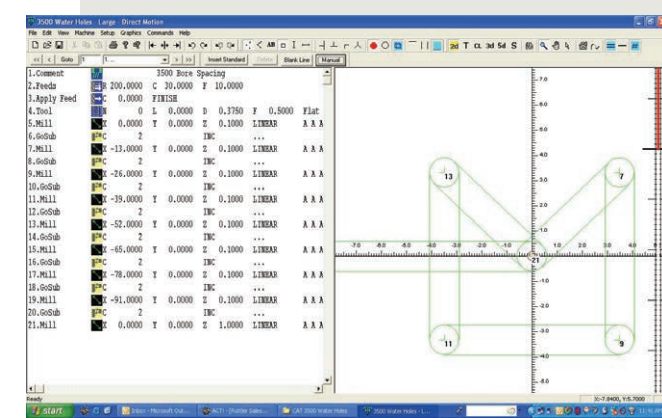

ROTTLER EXCLUSIVE TOUCH SCREEN PROGRAMMING

Control Summary

The conveniently located control pendant centralizes the machine controls. Only the buttons and interactive menus required for a particular machine operation are displayed. Machine operations can easily be done manually or automatically, with the ability to store programs in memory. Digital readout allows the operator to accurately monitor position at all times. Control operates in metric and inch systems.

Fully Programmable Cycles

Conversational three axis CNC control, PC based with Windows Operating System.

Dimensions and Control through Touch Screen:

- Program Bore Centers, Exact Depth, Speed, Feed, etc.
- Machines complete bank or main line in Automatic Cycle.
- Lower Offset Boring allows lower sleeve repair in Automatic Cycle.
- Circular Interpolate Counterbores for Radius Undercut or Wide Counterbores.
- Surfacing/Milling – Multiple Pass – program for Rough Cut and Finish Cut for superior surface finish.
- Line Boring – program the bearing bores and length of each bore and the machine automatically moves from bore to bore, completing the line unattended.
- Face Main Line Thrust Faces square to centerline of Crankshaft using Rottler Circular Interpolation software.

Features

Automatic

Programmable
PC Control/Windows

Versatile and Flexible

Variable Speeds & Feeds

AC Servo Motors

Power Drawbar

Hardened Boxway Bed

Turcite Coated Bedways

Precision Ball Screws

T-Slot Table

Benefits

Moves accurately from bore to bore unattended.

Saves all settings in memory for future use.
Can be easily updated for additional functions.

Bore, surface, line bore, ream, drill, tap, etc.
Allows surface finishes as low as 10Ra.

Maximum torque and performance at all speeds.

Quick, easy tool changing at the press of a button.

Ensures exceptional rigidity for accurate machining.

Reduced friction for smooth movement and long life.

Precision ball screws give accurate positioning.

Clamp any fixture and job quickly and easily.

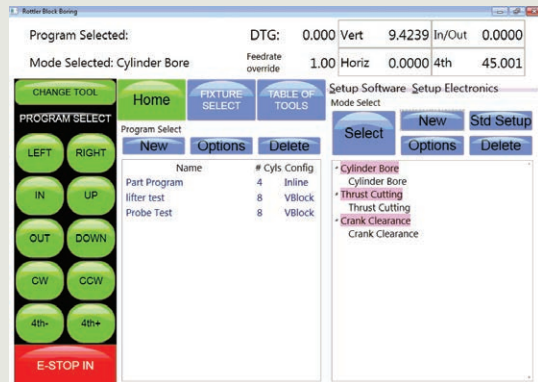

Mode Screen

Allows operator to select operation to perform. Information is saved in the computer's memory.

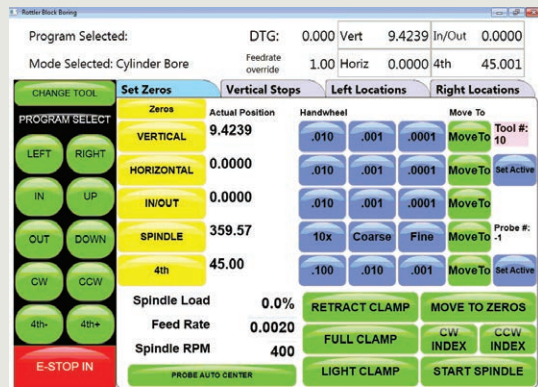

Set Zeros

Simply set zeroes to begin the setup of the job and start automatic cycle.



Vertical Stops

Enter length of bore, sleeve, counterbore, etc and the machine will bore to the exact depth. Lower Sleeve Repair allows a lower diameter that is larger than an upper diameter to be bored in one automatic cycle.

Centering - 3 methods



1. Blueprint

Enter centers of bores from blueprint drawing into touch screen and the machine will bore to exact blueprint dimensions.



2. Indicate

Center Cutterhead in bore using digital or dial gage then touch 'Set button' and the machine memorizes the bore center.

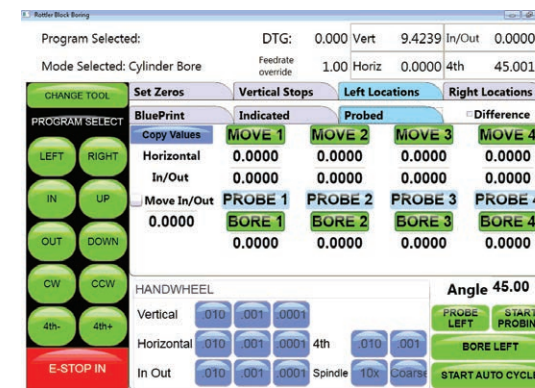

3. Probe

Machine will automatically probe all bores and memorize dimensions of centers and measures bore diameters.

After centering is completed, touch 'Auto Cycle' and the machine will automatically bore to the exact dimensions. These dimensions are saved under a block name for future use.

Versatility & Simplicity



Main & Cam Line Bore

Enter distance to each bore and length of each bore and the machine automatically bores the complete line.

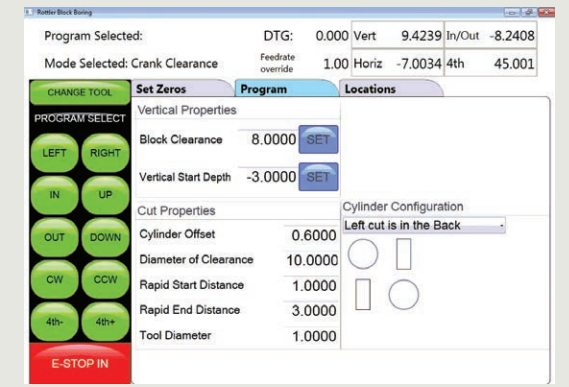

Thrust Cutting Main Line

Allows operator to easily program for thrust cutting using circular interpolation. Both sides of thrust can be machined in one automatic cycle.



Connecting Rod

Combined with Rottler Connecting Rod Fixtures, allows both big end and small end to be bored in one set up ensuring perfect parallelism and center to center distance.

SET UP AND MEASURING INSTRUMENTS

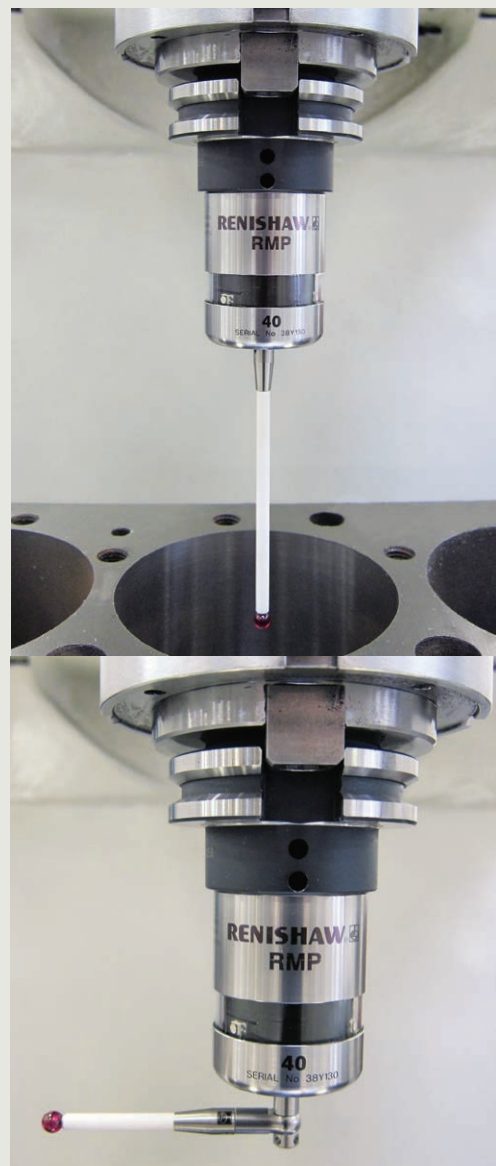

Rottler has a wide selection of micrometers, probes, indicators, setting fixtures and magnetic holders to allow versatile and accurate size setting for all machining requirements.

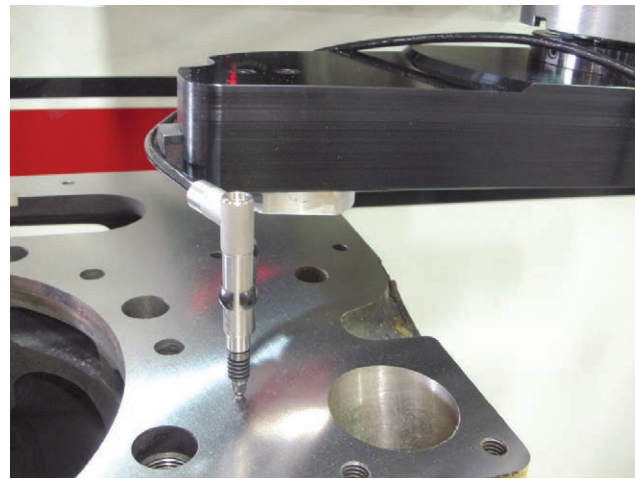

Digital Run Out Probe and Readout

The digital run out probe allows leveling and precise centering with digital readout on the control panel. Check level and alignment of decks, center in cylinder bores and main lines, etc.

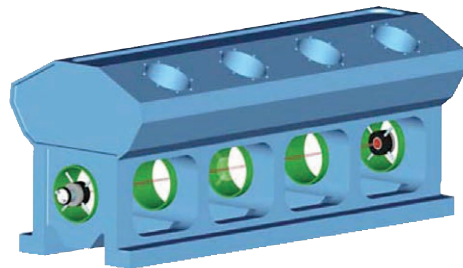
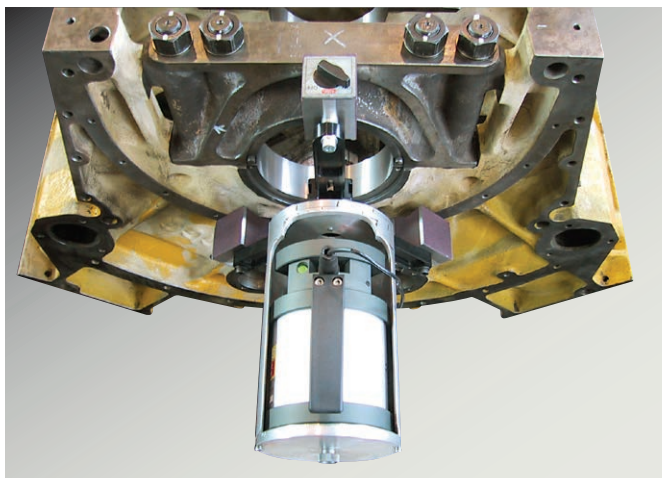

Laser Alignment

Engine Block Laser Alignment has provided engine machinists with a fast, reliable method of measuring straightness of a line bore. The laser system has proven to decrease inspection times significantly and virtually eliminated dedicated, expensive gauging. Computer printed results are available for future reference. Laser allows shop owners to explain requirements for line boring to customers

Wireless Radio Probing

Computer controlled wireless probe automatically finds cylinder bore centers and at the same time measures bore diameters. The difference between the drawing blueprint and the probed dimensions can be displayed by touching one button.

The deck (head gasket face) can be probed to check flatness and squareness to ensure accuracy and minimum metal removal when surfacing.

Upper and Lower Centering

With the use of a radio probe, the upper and lower bores of wet liner blocks can be probed to check concentricity and perpendicularity to ensure that the block is set up correctly before machining.

TOOLING & CUTTERHEADS

Spindle Adapters

The Rottler Spindle Taper allows a wide selection of spindle adapters which allows the use of a wide variety of industrial tooling. ISO 40, R8, Morse Taper #5 and 1" (25.4mm) are available. Rottler also has a blank spindle adapter to allow customers to machine and adapt special requirements.

Milling Cutter Holders

Collet Chuck Kits with CAT40 taper allow milling tools such as end mills, slot drills and reamers to be used.

Flycutters and Milling Heads

Surfacing with the F100 machine can be done during the same set up as boring. 10" (250mm) and 14" (360mm) flycutters can be used with CBN inserts for high speed dry surfacing giving excellent surface finish results. The deck of a large block such as a V12 can be surfaced in less than 10 minutes.

Multi Tool Milling Head

Multi Teeth Milling Heads can be used for milling welded and spray built up surfaces. Small diameter milling heads are ideal for facing main bearing housing contact surfaces in preparation for line boring to standard diameter. Special Surfacing Software allows very wide surfaces up to to be surfaced.

Boring Cutterheads

Rottler manufactures a complete range of quick change boring cutterheads for boring and sleeving operations from .750" (19mm) to 7" (178mm). The air assisted quick change retention system minimizes down time between tooling changes. Cutterheads can be changed in seconds!



CUTTING INSERTS

Rottler's tag line is 'The Cutting Edge', and we take pride in offering many different grades of cutting inserts for dry, high speed cutting a wide variety of materials. Decades of experience machining engines worldwide allows Rottler machines to dry cut a wide variety of parts. **CBN inserts** give exceptional long life for surfacing gasket faces as well as produce fine surface finishes for reliable sealing of metal gaskets. Dry CBN surfacing eliminates the need for wet grinding and at the same time gives flatter surfaces as cutting pressure is substantially reduced compared to surface grinding. **PCD inserts** allow soft metals such as Aluminum to be surfaced at high speed without coolant.

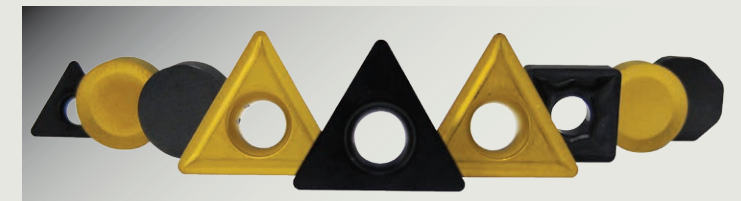

Rottler offers several different grades of **indexable carbide inserts** for cylinder boring & sleeving and main & cam line boring. **Special Black coated carbide inserts** are capable of standard to heavy sleeve cuts up to 1000rpm. **Triangle inserts** work well where cutting a bore to a square shoulder is needed, such as sleeves and counterbores. **Finishing Inserts** provide a sharper edge which results in a smoother surface finish on the cutting surface, ideal for finishing counterbores. **Carbide inserts** are available with 1/64" (0.4mm) and 1/32" (0.8mm) corner radius. Specially custom sharpened tools are available for operations such as chamfering, O-ring grooving, undercutting and blind hole boring.

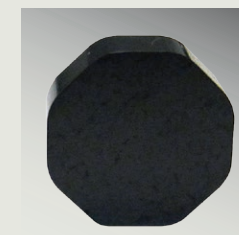

Octagonal Cutting Inserts

New Octagonal 16 Cutting Corner Surfacing Inserts have increased corner radius to allow faster feed rates and finer surface finish.

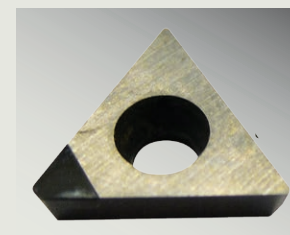

PCD Tipped Insert for Boring Aluminum

PCD cutting corner allows aluminum to be bored at high speed without any coolant.

FIXTURES

Rottler manufactures a selection of universal fixtures to allow a wide variety of jobs, small and big! Boring, Surfacing, Line Boring and general machining of most all jobs can be done on the versatile F100 machines.

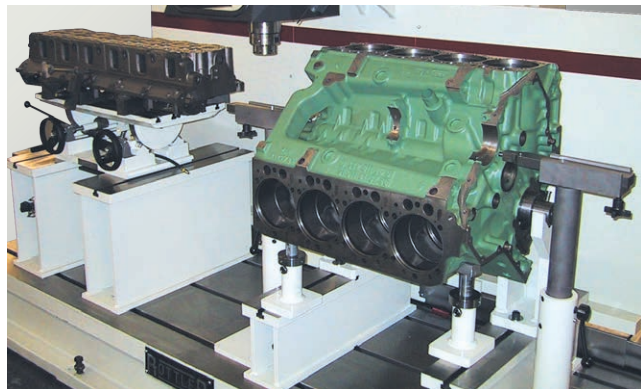
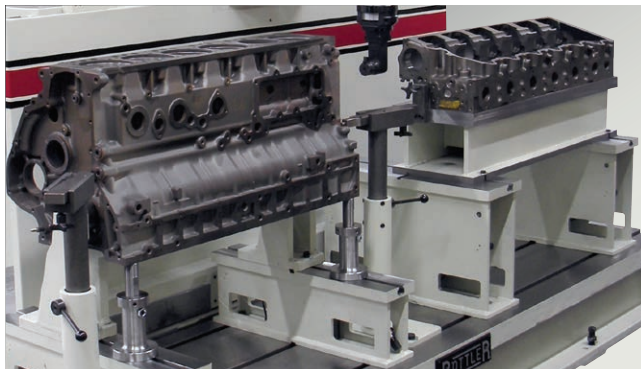

Dual Axis Leveling Table

Rottler's answer to holding a wide variety of cylinder heads from a single cylinder to a large 6 cylinder diesel. The Rottler Dual Axis Leveling Table allows clamping of the head to be completed first, then the level adjusted in both directions simply by rotating the two hand wheels! Combined with Rottler's Dual Axis Level, any job can be clamped and leveled in seconds! This process results in minimum stock removal when surfacing.

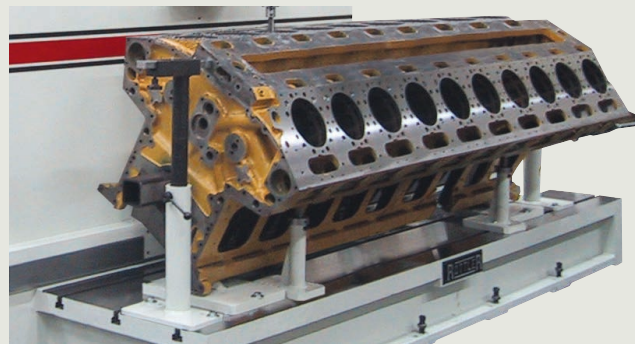
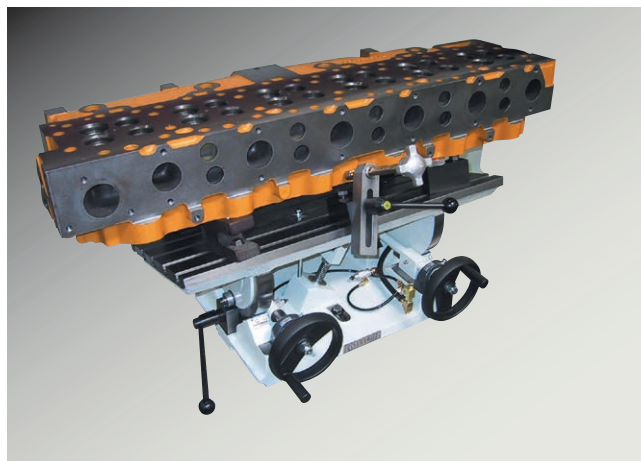

Dual Work Stations

Rottler's versatile fixtures and open sided T-Slot work table allow in-line and V- blocks to be mounted on the same fixture. A second operation such as head surfacing or line boring can be done on a second fixture without removing the part from the other fixture. Blocks are set up with reference to their main centerline ensuring that the decks are parallel and the counterbores are square to the main centerline. Universal quick clamp tower type hold down assemblies makes clamping easy and rigid.

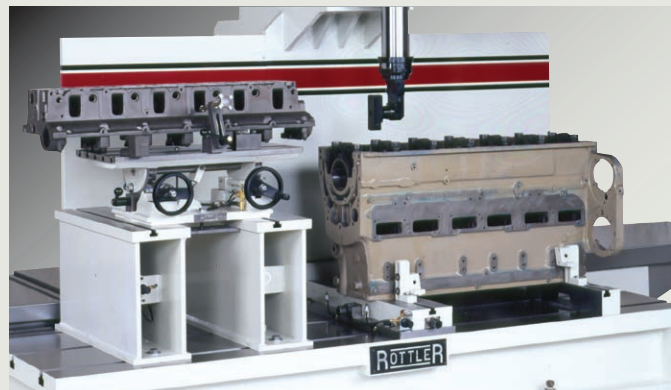

Line Bore Pivot Table

Rottler's Line Bore Pivot Table allows small blocks and cylinder heads to be set up and adjusted for line boring. The T-Slot Table allows versatile clamping of a wide variety of jobs.

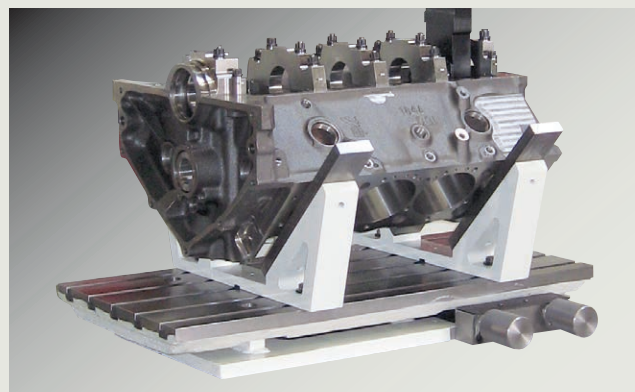

Dual Axis Level

Displays both axes simultaneously allowing quick leveling, eliminating any need for shimming and resulting in minimum metal removal when surfacing cylinder heads.



LARGE CONNECTING ROD MACHINING

Connecting Rod Fixtures

Rottler's patented Connecting Rod Fixtures allow large connecting rods to be surfaced and bored on the F100 machines. The Rottler boring fixtures allow both big end and small end to be bored in one set up resulting in perfect parallelism between big end and small end. All the rods in a set can be accurately bored for equal center to center distance, a must for today's high compression diesel engines. Special heavy duty fixtures available for boring very large, heavy connecting rods found in natural gas compressors and workboat marine engines are available.

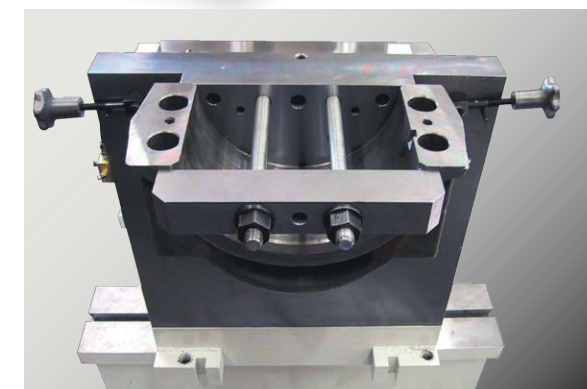
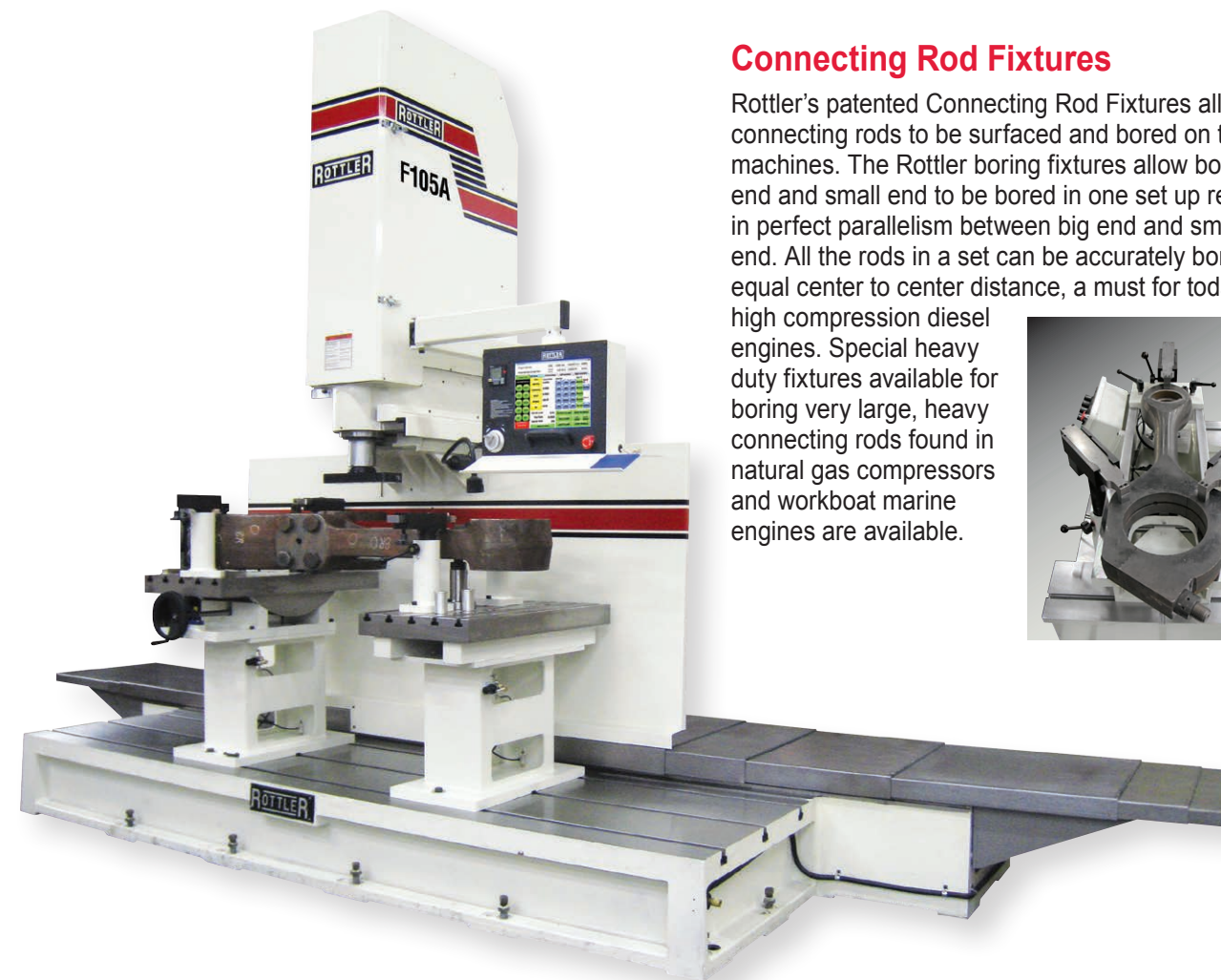

Surfacing Fixture

Heavy Duty surfacing fixture to prepare Natural Gas Compressor Rods for boring.

Leveling Table

Rottler's Dual Axis Leveling Table with two piece vice used for surfacing Connecting Rod Caps and Main Bearing Housings in preparation for main line boring.

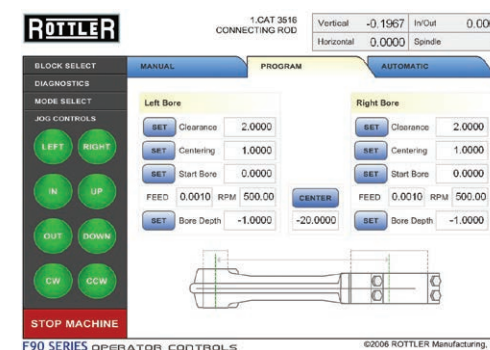

Connecting Rod Touch Screen Control



LINE BORING

Over 20 years ago, Rottler pioneered right angle drive line boring and today are world leaders in this field. During these years, Rottler has developed a wide variety of tooling and fixtures so that blocks and heads can be easily and quickly set up and machined fast, automatically and accurately. Programming is simple and variable feedrate controlled by the hand wheel during automatic cycles allow operators to easily learn to program and operate these machines without accidents and down time.

Bar Sag Error associated with horizontal bar type machines is totally eliminated! Machining lines is considerably faster and size control is consistently within a fine tolerance. Thrust facing using Rottler circular interpolation software can be done in the same set up ensuring perfect squareness with bearing centerline.

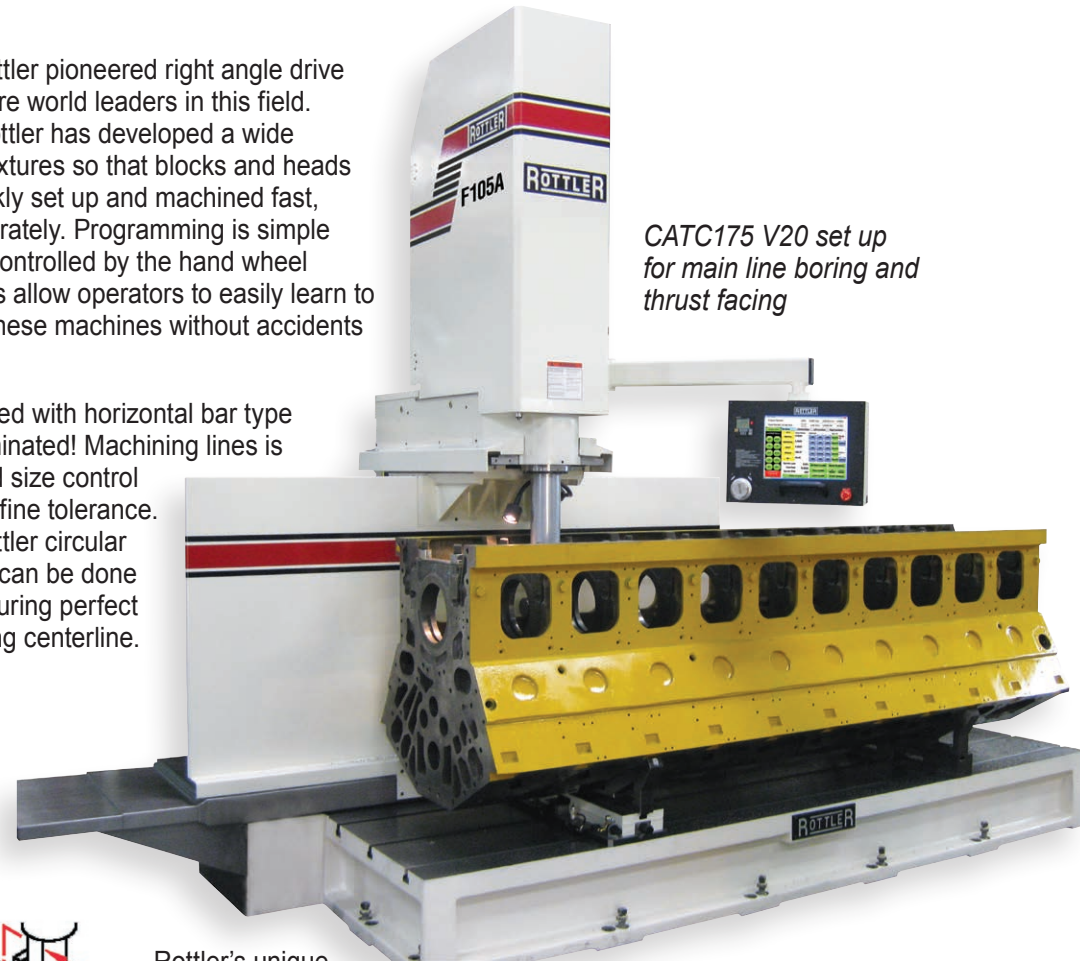

CATC175 V20 set up for main line boring and thrust facing

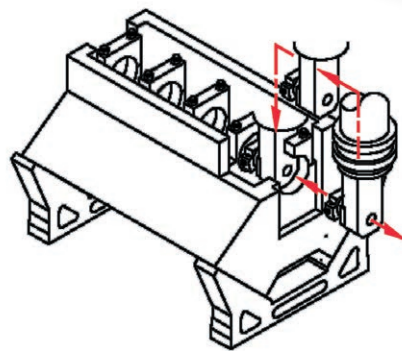

Rottler's unique right angle drives machine each bore individually and the digital display ensures perfect accuracy and alignment.



The F100 series are able to machine main bearing cap registers in the block to ensure they are perfectly flat for maximum contact with main bearing caps. At the same time, the diameter is reduced for line boring back to standard diameter.



Special steel main bearing housings found in high power diesel engines such as MTU 4000 require high speed machining to obtain superior accuracy of roundness, straightness, parallelism and surface finish.

Line Bore Tooling

Rottler's Unique Right Angle Drive Line Boring Attachments allow for accurate machining of bearing lines from small cylinder heads such as CAT3406 and Detroit 50/60 Series up to large blocks such as CAT3520 and Waukesha 9390. Special cutterheads with micro adjust tools are available from Rottler's engineering department. Repairs such as sleeving and cutting spray weld can be done. Operators prefer this system as there is no bar in their way when measuring and boring/repairing bearing housings.

Special steel main bearing housings found in high power diesel engines such as MTU 4000 require high speed machining to obtain superior accuracy of roundness, straightness, parallelism and surface finish.



Line Bore Fixtures

Heavy duty fixtures allow heavy blocks such as CAT3520, Waukesha 9390, White Superior 825, MTU4000, etc to be set up and adjusted for line boring. Adjustable fixtures are air floated to allow easy positioning on the machine's work table.

(See Line Bore Pivot Table on page 12 under Fixtures)

Thrust Facing

Rottler's unique circular interpolation software and thrust facing tooling allow thrust faces to be machining perfectly square to bearing centerline using the same right angle drive that is used for line boring. Single point cutting allows build up to be removed without chatter resulting in fine surface finish.

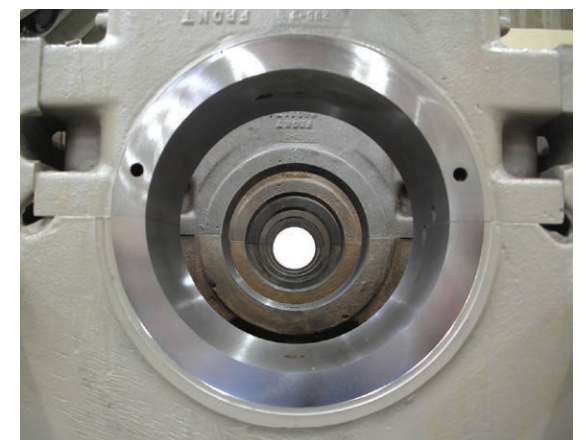
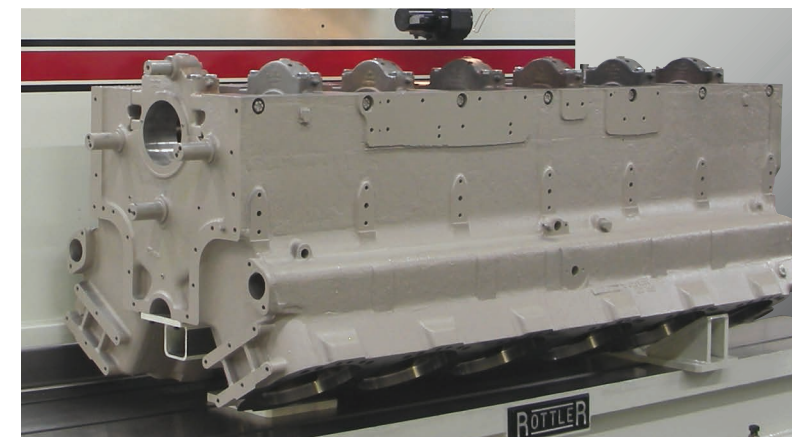

F100 SPECIFICATIONS

	American	Metric
Maximum Height – Table to Spindle Taper	50.1"	1273mm
Table Size – 3 T Slots:		
F103A	35" x 86"	890 x 2185mm
F104A	35" x 112"	890 x 2850mm
F105A	35" x 137"	890 x 2850mm
Maximum Distance – Spindle Center to Column	25.5"	648mm
Horizontal Column Travel (X Axis):		
F103A	84"	2135mm
F104A	109"	2770mm
F105A	134"	3400mm
Vertical Spindle Travel (Z Axis)	29"	720mm
Work Head Travel In/Out (Y Axis)	16"	406mm
Spindle Speeds Infinitely Variable	0 - 1000 RPM	
Spindle Motor	17 HP	12.75 kW
Cylinder Bore Range with Optional Cutterheads	.75" - 20"	19 - 508mm
Line Bore Range with Optional Cutterheads	1.9" - 8.5"	48.5 - 216mm
Surfacing Cutterhead Diameters	10", 14", 18", 22"	250, 360, 460, 570mm
Floor Space Requirements*:		
F103A	180" x 92"	4.5 x 2.44m
F104A	206" x 92"	5.23 x 2.44m
F105A	231" x 92"	5.87 x 2.44m
Machine Weight:		
F103A	14,000 lbs	6,360kgs
F104A	16,000 lbs	7,270kgs
F105A	18,000 lbs	8,180kgs
Electrical Requirement**	208-240V, 100A, 50/60Hz, 3Ph	
Air Requirement	1 cf/min @ 100 psi	28 L/min @ 6 Bar
Paint Color Code	RAL9002 (Grey White)	

*Does not allow for clearance to open electrical panel

**Optional transformer required for voltage above or below range.

Specifications and design subject to change without notice.

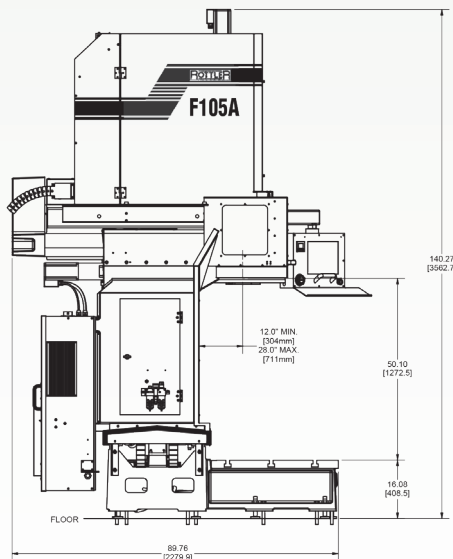

February 2013

www.rottlermfg.com

8029 South 200th Street
Kent, Washington 98032 USA

Represented by:

www.youtube.com/rottlermfg
www.facebook.com/rottlermfg
email: contact@rottlermfg.com

+1 253 872 7050

1-800-452-0534