

One of a family of rugged, heavy-duty flange facers with facing AND milling capabilities.

Rugged Machine Design

- Large, heavy duty construction-grade bearings provide powerful, rigid performance throughout the entire machine facing range, even machining over bolt hole patterns.
- Oversized ring gear accommodates extremely high torque levels for challenging flange repair applications, and these machines are able to generate a phonographic finish.

Flexible and Versatile

- Both radial and axial feed is achieved with a pneumatic feedbox. Manual feeding for rapid positioning is also possible.
- Feed rate is adjusted remotely at the pneumatic conditioning unit, providing the ultimate in operator safety and the flexibility for feed rate adjustments even during machining operations.
- Infinitely variable feed rates from 0.002 - 0.035 inches (0.0508 - 0.889 mm)/ rev provides operational flexibility.
- Reversible feed box can be mounted to provide either radial or axial feed.
- Turning and counterweight arms can both be adjusted for the desired swing clearance and machining range.
- Tool head can be rotated a full 360° providing the ability to create a variety of



chamfers, O-Ring grooves, lens rings and other angular surfaces as needed.

- Pneumatic & hydraulic drive options available.
- Chucking system can be removed to allow the flange facer to be face-mounted.
- Can be mounted both OD and ID
- Milling option available with precision downfeed ball screw
- Grinding option available for fine finish work.

Quick and Easy Setup

- Modular design allows many of the machine components to be removed to facilitate easier setup and storage.
- Unique chucking system minimizes parts to greatly simplify machine setup and tear down.
- Quick-adjust leveling feet make setup quick and easy.



SPECIFICATIONS

	US	Metric
Machine Performance Ranges		
ID: Mounting range	45 - 120 inches	1143.0 - 3048.0 mm
Facing diameter range	45 - 120 inches	1143.0 - 3048.0 mm
Milling diameter range	45 - 120 inches	1143.0 - 3048.0 mm
Grinding diameter range	45 - 120 inches	1143.0 - 3048.0 mm
Swing diameter @ minimum with feedbox on end of arm	84.7 inches	2151.4 mm
Radial tool slide travel	12 inches	304.8 mm
Axial tool head travel	4 inches	101.6 mm
Depth required inside bore for ID chuck (± 0.25 inches (± 6.4 mm) is travel of leveling foot)	12.13 ± 0.25 inches	308.1 ± 6.4 mm
Feed Rate	0.002 - 0.040 in/rev	0.051 - 1.016 mm/rev
OD: Mounting range *	89.8 - 136.4 inches	2280.9 - 3464.6 mm
Facing diameter range	45 - 120 inches	1143.0 - 3048.0 mm
Milling diameter range	45 - 113.5 inches	1143.0 - 2882.9 mm
Grinding diameter range (w/ feed box)	45 - 118 inches	1143.0 - 2997.2 mm
Grinding diameter range (w/o feed box)	45 - 120 inches	1143.0 - 3048.0 mm
Refer to ID for specifications not listed		
Milling Option: Vertical Stroke, milling head	8 inches	203.2 mm
Rotational Drive System		
Drive type	Pneumatic or hydraulic drive with pinion and internal ring gear	
Pinion gear to ring gear reduction	7.429:1	
Single point turning speed range:		
Pneumatic	5 - 29 RPM	
Hydraulic (based on motor choice)	1.8 - 18 RPM	
Milling & grinding speed ranges (with reducer):		
Pneumatic (rapid only, not in cut)	0.004 - 0.173 RPM (58 ipm @ 72 inch dia.)	(1473.2 mm/min @ 1828.8 mm dia.)
Hydraulic (based on motor choice)	0.002 - 0.374 RPM	
Power input requirements		
Pneumatic - 3.5 Hp (2.6 kW)	50 ft ³ /min @ 90 psi	1.42 m ³ /min @ 620 kPa
Hydraulic	10 gpm@1200 psi	37.9 L/min @ 8273 kPa
Measures		
For machine dimensions, please refer to dimensional drawings		
ID machine weight, approximate	4000 lb	1814.4 kg
ID machine weight with mill, approximate	4150 lbs	1882.4 kg
OD machine weight, approximate	3775 lb	1712.3 kg
ID machine weight with mill, approximate	3925 lbs	1780.4 kg
Chuck crate dimensions, (for ID and OD machines) (WxDxH)		
Wood, approx.	93 x 40.5 x 40 in	2362 x 1029 x 1016 mm
Metal, approx.	90.2 x 40.2 x 36.2 in	2291 x 1021 x 920 mm
Leg crate dimensions (for ID and OD machines) (WxDxH)		
Wood, approx.	94 x 43.5 x 19 in	2388 x 1105 x 483 mm
Metal, approx.	94.2 x 42.7 x 19.2 in	2393 x 1085 x 488 mm
OD mount hardware crate dimensions (for OD machine only) (WxDxH)		
Wood, approx.	94 x 43.5 x 19 in	2388 x 1105 x 483 mm
Metal, approx.	94.2 x 42.7 x 19.2 in	2393 x 1085 x 488 mm

* OD mount minimum arm swing is 40 inches (1016 mm) diameter. An additional customer supplied structure will be required to chuck below the minimum swing diameter

All dimensions should be considered reference. Contact your Climax Representative for precision dimensions. Specifications are subject to change without notice. There are no systems or components on this machine that are capable of producing hazardous EMC, UV or other radiation hazards. The machine does not use lasers nor does it create hazardous materials such as gasses or dust.

TOOL CONFIGURATIONS

The FF8200 can be configured in several ways to meet your specific machining needs.

Select [OPTION 1](#) for [single pointing only](#)

Select [OPTION 2](#) for [milling only](#)

Select [OPTION 3](#) for [BOTH milling and single pointing](#)

OPTION 1: To configure your FF8200 for Single Pointing Only

To configure your machine, please follow these steps.

1	Select a Base Package				
2	Select a Feed Assembly				
3	Select a Drive Motor Assembly				
4	Select a Hydraulic Motor				
5	Select an Optional Grinder Attachment				
6	Select a Hydraulic Power Unit				
7	Select a Turning Arm Assembly				
8	Select a Counterweight Assembly				
9	Select a Chuck Assembly				
10	Select a Shipping Container				
1	Base Package				
	Rotary table, tool kit, operator's manual .	58187			
2	Feed Assembly				
	Pneumatic Feed Assembly with Remote Air Control	58671			
3	Drive Motor Assembly				
	Pneumatic Motor and Drive Assembly	58186			
	(Pneumatic drive system includes: Pneumatic motor w/fittings and mount, rotary union, hoses, feed trip valve, cam, and pneumatic conditioning unit with low pressure drop out.)				
	Hydraulic Drive Assy w/ Feed Conditioning Unit - DOES NOT INCLUDE MOTOR	58180			
	(Hydraulic drive system includes: Hyd motor mount, hoses, fittings, rotary union, feed trip valve, cam, and feed pneumatic conditioning unit.)				
4	Hydraulic Motor for Rotary Table Drive				
	(If Hydraulic drive is selected in step 3)				
	Rated at 10 gpm, 1200 PSI				
	Hydraulic Motor, 14.9 cu in (244.2 cu cm), 3.6 - 18 RPM	69216			
	Hydraulic Motor, 18.7 cu in (306.4 cu cm), 2.8 - 14 RPM	69217			
	Hydraulic Motor, 24.0 cu in (393.3 cu cm), 2.2 - 11 RPM	69218			
	Hydraulic Motor, 29.8 cu in (488.3 cu cm), 1.8 - 9 RPM	69219			
	* Multiple units may be ordered.				
5	Optional Grinder Attachment				
	Grinding Attachment for Pneumatic Table Drive Motor	62537			
	Grinding Attachment for Hydraulic Table Drive Motor	62570			
	Grinder Rotational Gearbox				
	Slow Rotation Gearbox for Pneumatic Motor (gear ratio 160:1)	62568			
	Slow Rotation Gearbox for Hydraulic Motor (gear ratio 160:1)	62538			
	Grinder Tooling				
	Grinding Wheel 1.5 in (38.1 mm), CBN 130 Grit	62633			
	Grinding Wheel 2.25 in (57.2 mm), CBN 130 Grit	62634			
	6 Hydraulic Power Unit				
	For Hydraulic Drive Machine				
	Single Pump (single pointing only):				
	HPU 230V, 10 HP (7.5 kW) Single pump			63264	
	HPU 380V, 10 HP (7.5 kW) Single pump			63265	
	HPU 415V, 10 HP (7.5 kW) Single pump			63266	
	HPU 460V, 10 HP (7.5 kW) Single pump			63267	
	HPU 575V, 10 HP (7.5 kW) Single pump			63268	
	Single Pump with Air (for use with grinder):				
	HPU 230V, 10 HP (7.5 kW) Single pump with Air			62759	
	HPU 380V, 10 HP (7.5 kW) Single pump with Air			62760	
	HPU 415V, 10 HP (7.5 kW) Single pump with Air			62761	
	HPU 460V, 10 HP (7.5 kW) Single pump with Air			62762	
	HPU 575V, 10 HP (7.5 kW) Single pump with Air			62763	
	Pendant Cable and Hose				
	0.5 in (12.7 mm) Hose and Pendant Cable Assy, 20 ft (6.1 m)			62799	
	0.5 in (12.7 mm) Hose and Pendant Cable Assy, 30 ft (9.1 m)			62800	
	0.5 in (12.7 mm) Hose and Pendant Cable Assy, 50 ft (15.2 m)			62801	
	0.5 in (12.7 mm) Hose and Pendant Cable Assy, 100 ft (30.5 m)			62802	
	7 Turning Arm Assembly				
	Turning Arm Assembly with Single Point Tool Head			57872	
	Milling Arm Assembly with Single Point Tool Head			62578	
	8 Counterweight Assembly				
	Counterweight Assembly			58066	
	Counterweight Milling Arm Assembly			62515	
	9 Chuck Assembly				
	ID Chuck Assembly			57881	
	OD Chuck Assembly			61372	
	ID/OD Chuck Assembly			61454	
	10 Shipping Container				
	Wooden Crate for ID Mount Machine			58421	
	Metal Container for ID Mount Machine			59936	
	Wooden Crate Set for ID/OD Mount Machine			62679	
	Metal Container Set for ID/OD Mount Machine			61724	

TOOL CONFIGURATIONS

OPTION 2: To configure your FF8200 for Milling Only

To configure your machine, please follow these steps.

1	Select a Base Package				
2	Select a Drive Motor Assembly				
3	Select a Hydraulic Motor				
4	Select an Optional Grinder Attachment				
5	Select a Hydraulic Power Unit				
6	Select a Turning Arm Assembly				
7	Select a Counterweight Assembly				
8	Select a Milling Head				
9	Select a Hydraulic Motor				
10	Select Tooling				
11	Select a Chuck Assembly				
12	Select a Shipping Container				
1	Base Package				
	Rotary table, tool kit, drag brake assemblies, operator's manual.	62673			
2	Drive Motor Assembly				
	Pneumatic Motor and Drive Assembly (Pneumatic drive system includes: Pneumatic motor w/fittings and mount, gearbox, rotary union, hoses, feed trip valve, and pneumatic conditioning unit with low pressure drop out.)	62571			
	Hydraulic Drive Assy w/Gearbox - DOES NOT INCLUDE MOTOR OR PNEUMATIC SYSTEM (Hydraulic drive system includes: Hyd motor mount, gearbox, hoses, fittings, and rotary union.)	62585			
3	Hydraulic Motor for Rotary Table Drive (If Hydraulic drive is selected in step 2)				
	Rated at 10 gpm, 1200 PSI				
	Hydraulic Motor, 4.9 cu in (80.3 cu cm), 0.1 - 0.35 RPM	69213			
	Hydraulic Motor, 8.0 cu in (131.1 cu cm), 0.05 - 0.20 RPM	69214			
	Hydraulic Motor, 14.9 cu in (244.2 cu cm), 0.02 - 0.11 RPM	69216			
	Hydraulic Motor, 29.8 cu in (488.3 cu cm), 0.012 - 0.06 RPM	69219			
	* Multiple units may be ordered.				
4	Optional Grinder Attachment				
	Grinding Attachment for Pneumatic Table Drive Motor (tool head included)	62948			
	Grinding Attachment for Hydraulic Table Drive Motor (tool head included)	62947			
	Grinder Tooling				
	Grinding Wheel 1.5 in (38.1 mm), CBN 130 Grit	62633			
	Grinding Wheel 2.25 in (57.2 mm), CBN 130 Grit	62634			
5	Hydraulic Power Unit				
	Single Pump (for pneumatic table rotation):				
	HPU 230V, 25HP Single pump with Air	62774			
	HPU 380V, 25HP Single pump with Air	62775			
	HPU 415V, 25HP Single pump with Air	62776			
	HPU 460V, 25HP Single pump with Air	62777			
	HPU 575V, 25HP Single pump with Air	62778			
	Dual Pump (with air) for hydraulic table rotation and hydraulic milling head, and air for grinding attachment:				
	HPU 230V, 25HP Dual Pump with Air	62779			
	HPU 380V, 25HP Dual Pump with Air	62780			
	HPU 415V, 25HP Dual Pump with Air	62781			
	HPU 460V, 25HP Dual Pump with Air	62782			
	HPU 575V, 25HP Dual Pump with Air	62783			
	hydraulic milling head)				
	HPU 230V, 25HP Dual Pump	62784			
	HPU 380V, 25HP Dual Pump	62785			
	HPU 415V, 25HP Dual Pump	62786			
	HPU 460V, 25HP Dual Pump	62787			
	HPU 575V, 25HP Dual Pump	62788			
	Pendant Cable & Hose, Single Pump				
	0.75 in (19.1 mm) Hose and Pendant Cable Assy, 20 ft (6.1 m)	62803			
	0.75 in (19.1 mm) Hose and Pendant Cable Assy, 30 ft (9.1 m)	62804			
	0.75 in (19.1 mm) Hose and Pendant Cable Assy, 50 ft (15.2 m)	62805			
	0.75 in (19.1 mm) Hose and Pendant Cable Assy 100 ft (30.75 m)	62806			
	Pendant Cable & Hose, Dual Pump				
	0.5 in (12.7 mm) & 0.75 in (19.1 mm) Dual Hose & Pendant Cable Assy, 20 ft (6.1 m)	62807			
	0.5 in (12.7 mm) & 0.75 in (19.1 mm) Dual Hose & Pendant Cable Assy, 30 ft (9.1 m)	62808			
	0.5 in (12.7 mm) & 0.75 in (19.1 mm) Dual Hose & Pendant Cable Assy, 50 ft (15.2 m)	62809			
	0.5 in (12.7 mm) & 0.75 in (19.1 mm) Dual Hose & Pendant Cable Assy, 100 ft (30.5 m)	62810			
6	Turning Arm Assembly				
	Milling Arm Assembly (does not include tool head)	60870			
7	Counterweight Assembly				
	Counterweight Milling Arm Assembly	62415			
8	Milling Head				
	Milling Head Assembly Inch #50 Taper NMTB	62282			
	Milling Head Assembly Inch #50 Taper CATV	62734			
	Milling Head Assembly Metric #50 Taper NMTB	62644			
	Milling Head Assembly Metric #50 Taper CATV	62735			
9	Tooling (for inch milling head assembly only)				
	#50, NBTB 4 in (101.6 mm) Face Mill w/ Inserts	47383			
	#50, NBTB 5 in (127.0 mm) Face Mill w/ Inserts	47384			
	#50, NBTB 6 in (152.4 mm) Face Mill w/ Inserts	47385			
	#50, NBTB 8 in (203.2 mm) Face Mill w/ Inserts	47386			
	#50, NBTB 10 in (254.0 mm) Face Mill w/ Inserts	56175			
	Carbide Inserts	47229			
10	Milling Head Swivel Assembly				
	Milling Head Swivel Plate Assembly	63250			
11	Hydraulic Motor for Milling Head				
	Hydraulic Motor Assembly 8.0 cu in (131.1 cu cm)	53459			
	Hydraulic Motor Assembly 9.6 cu in (157.3 cu cm)	53458			
	Hydraulic Motor Assembly 11.9 cu in (195.0 cu cm)	46950			
	Hydraulic Motor Assembly 14.9 cu in (244.2 cu cm)	46375			
	Hydraulic Motor Assembly 18.7 cu in (306.4 cu cm)	46549			
	Hydraulic Motor Assembly 24.0 cu in (393.3 cu cm)	46550			
12	Chuck Assembly				
	ID Chuck Assembly	57881			
	OD Chuck Assembly for Turning with Milling Arm	62666			
	ID/OD Chuck Assembly for Turning with Milling Arm	62674			
13	Shipping Container				
	Wooden Crate for ID Mount Machine	58421			
	Metal Container for ID Mount Machine	59936			
	Wooden Crate Set for ID/OD Mount Machine	62679			
	Metal Container Set for ID/OD Mount Machine	61724			

Dual Pump (for hydraulic table rotation and

TOOL CONFIGURATIONS

OPTION 3: To configure your FF8200 for Milling, or Milling with Single Pointing

To configure your machine, please follow these steps.

1	Select a Base Package	9	Select a Milling Head	and hydraulic milling head):	
2	Select a Feed Assembly	10	Select a Tooling	HPU 230V, 25HP Dual Pump	62784
3	Select a Drive Motor Assy	12	Select a Chuck Assembly	HPU 380V, 25HP Dual Pump	62785
4	Select a Hydraulic Motor	13	Select a Shipping Container	HPU 415V, 25HP Dual Pump	62786
5	Select an Optional Grinder			HPU 460V, 25HP Dual Pump	62787
6	Select a Hydraulic Power Unit			HPU 575V, 25HP Dual Pump	62788
7	Select a Turning Arm Assembly	1	Base Package	Pendant Cable & Hose, Single Pump	
8	Select a Counterweight Assy			0.75 in (19.1 mm) Hose and Pendant Cable Assy, 20 ft (6.1 m)	62803
	Rotary table, tool kit, drag brake assemblies, operator's manual.	62670		0.75 in (19.1 mm) Hose and Pendant Cable Assy, 30 ft (9.1 m)	62804
2	Feed Assembly			0.75 in (19.1 mm) Hose and Pendant Cable Assy, 50 ft (15.2 m)	62805
	Pneumatic Feed Assembly w/ Remote Air Control	58671		0.75 in (19.1 mm) Hose and Pendant Cable Assy, 100 ft (30.75 m)	62806
3	Drive Motor Assembly			Pendant Cable & Hose, Dual Pump	
	Pneumatic Motor and Drive Assembly (Pneumatic drive system includes: Pneumatic motor w/fittings and mount, gearbox, rotary union, hoses, feed trip valve, cam, & pneumatic conditioning unit with low pressure drop out.)	62591		0.5 in (12.7 mm) & 0.75 in (19.1 mm) Dual Hose & Pendant Cable Assy, 20 ft (6.1 m)	62807
	Hydraulic Drive Assy w/Gearbox & Feed Conditioning Unit - DOES NOT INCLUDE MOTOR (Hydraulic drive system includes: Hyd motor mount, gearbox, hoses, fittings, rotary union, feed trip valve, cam, and feed pneumatic conditioning unit.)	62594		0.5 in (12.7 mm) & 0.75 in (19.1 mm) Dual Hose & Pendant Cable Assy, 30 ft (9.1 m)	62808
4	Hydraulic Motor for Rotary Table Drive (If Hydraulic drive is selected in step 3)			0.5 in (12.7 mm) & 0.75 in (19.1 mm) Dual Hose & Pendant Cable Assy, 50 ft (15.2 m)	62809
	Rated at 10 gpm, 1200 PSI			0.5 in (12.7 mm) & 0.75 in (19.1 mm) Dual Hose & Pendant Cable Assy, 100 ft (30.5 m)	62810
	Fast RPM = Single Point Machining / Slow RPM = Milling			7	Turning Arm Assembly
	Hydraulic Motor, 4.9 cu in (80.3 cu cm), 16 - 56 RPM / 0.1 - 0.35 RPM	69213			Milling Arm Assembly with Single Point Tool Head
	Hydraulic Motor, 8.0 cu in (131.1 cu cm), 8 - 32 RPM / 0.05 - 0.20 RPM	69214		8	Counterweight Assembly
	Hydraulic Motor, 14.9 cu in (244.2 cu cm), 3.6 - 18 RPM / 0.02 - 0.11 RPM	69216			Counterweight Milling Arm Assembly
	Hydraulic Motor, 18.7 cu in (306.4 cu cm), 2.8 - 14 RPM / 0.018 - 0.09 RPM	69217		9	Milling Head
	Hydraulic Motor, 24.0 cu in (393.3 cu cm), 2.2 - 11 RPM / 0.014 - 0.07 RPM	69218			Milling Head Assembly Inch #50 Taper NMTB
	Hydraulic Motor, 29.8 cu in (488.3 cu cm), 1.8 - 9 RPM / 0.012 - 0.06 RPM	69219			Milling Head Assembly Inch #50 Taper CATV
	* Multiple units may be ordered.				Milling Head Assembly Metric #50 Taper NMTB
5	Optional Grinder Attachment				Milling Head Assembly Metric #50 Taper CATV
	Grinding Attachment for Pneumatic Table Drive Motor	62537		10	Tooling (for inch milling head assembly only)
	Grinding Attachment for Hydraulic Table Drive Motor	62570			#50, NBTB 4 in (101.6 mm) Face Mill w/ Inserts
	Grinder Tooling				#50, NBTB 5 in (127.0 mm) Face Mill w/ Inserts
	Grinding Wheel 1.5 in (38.1 mm), CBN 130 Grit	62633			#50, NBTB 6 in (152.4 mm) Face Mill w/ Inserts
	Grinding Wheel 2.25 in (57.2 mm), CBN 130 Grit	62634			#50, NBTB 8 in (203.2 mm) Face Mill w/ Inserts
6	Hydraulic Power Unit				#50, NBTB 10 in (254.0 mm) Face Mill w/ Inserts
	Single Pump (for pneumatic table rotation):				Carbide Inserts
	HPU 230V, 25HP Single pump with Air	62774		11	Milling Head Swivel Assembly
	HPU 380V, 25HP Single pump with Air	62775			Milling Head Swivel Plate Assembly
	HPU 415V, 25HP Single pump with Air	62776		12	Hydraulic Motor for Milling Head
	HPU 460V, 25HP Single pump with Air	62777			Hydraulic Motor Assembly 8.0 cu in (131.1 cu cm)
	HPU 575V, 25HP Single pump with Air	62778			Hydraulic Motor Assembly 9.6 cu in (157.3 cu cm)
	Dual Pump (with air) for hydraulic table rotation, hydraulic milling head, and air for grinding attachment:				Hydraulic Motor Assembly 11.9 cu in (195.0 cu cm)
	HPU 230V, 25HP Dual Pump with Air	62779			Hydraulic Motor Assembly 14.9 cu in (244.2 cu cm)
	HPU 380V, 25HP Dual Pump with Air	62780			Hydraulic Motor Assembly 18.7 cu in (306.4 cu cm)
	HPU 415V, 25HP Dual Pump with Air	62781			Hydraulic Motor Assembly 24.0 cu in (393.3 cu cm)
	HPU 460V, 25HP Dual Pump with Air	62782		13	Chuck Assembly
	HPU 575V, 25HP Dual Pump with Air	62783			ID Chuck Assembly
	Dual Pump (for hydraulic table rotation				OD Chuck Assembly for Milling Arm
					ID/OD Chuck Assembly for Milling Arm
				14	Shipping Container
					Wooden Crate for ID Mount Machine
					Metal Container for ID Mount Machine
					Wooden Crate Set for ID/OD Mount Machine
					Metal Container Set for ID/OD Mount Machine

SETUP AND OPERATION

A Fast Eight-Step Process

This model is so fast and easy to set up that an experienced operator can usually mount the machine into the flange bore, align it, and start cutting in less than an hour.

1 Measure the bore diameter. This will be used to determine the leg length.

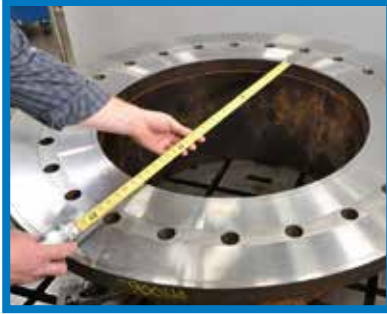

5 Set machine onto flange using setup fingers. Lightly tighten leveling feet in the flange.



2 Select the appropriate leg length and foot.



6 Extend feet into flange. Indicate, level and tighten leveling feet and stationary feet.



3 Install setup fingers.



7 Install tool bit. Connect to power.

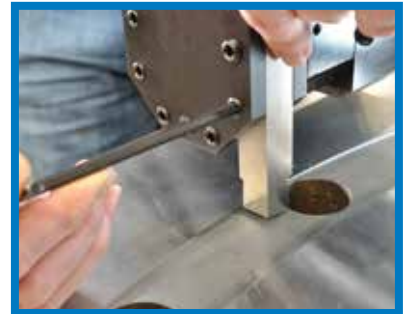

4 Tighten legs.



8 You are ready to begin machining!



OPERATIONAL DIMENSIONS

Dimensions in Inch (mm)

ID Chuck Assembly

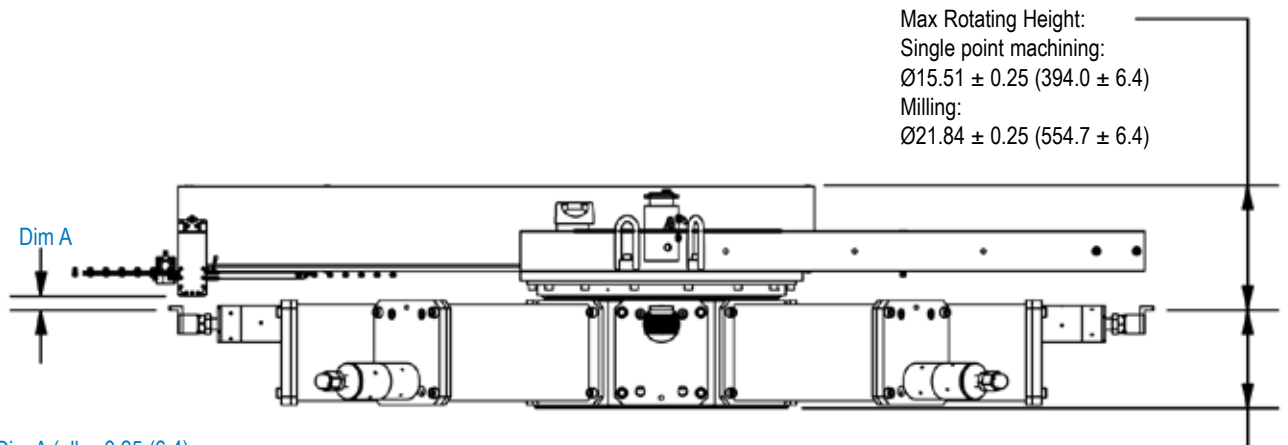
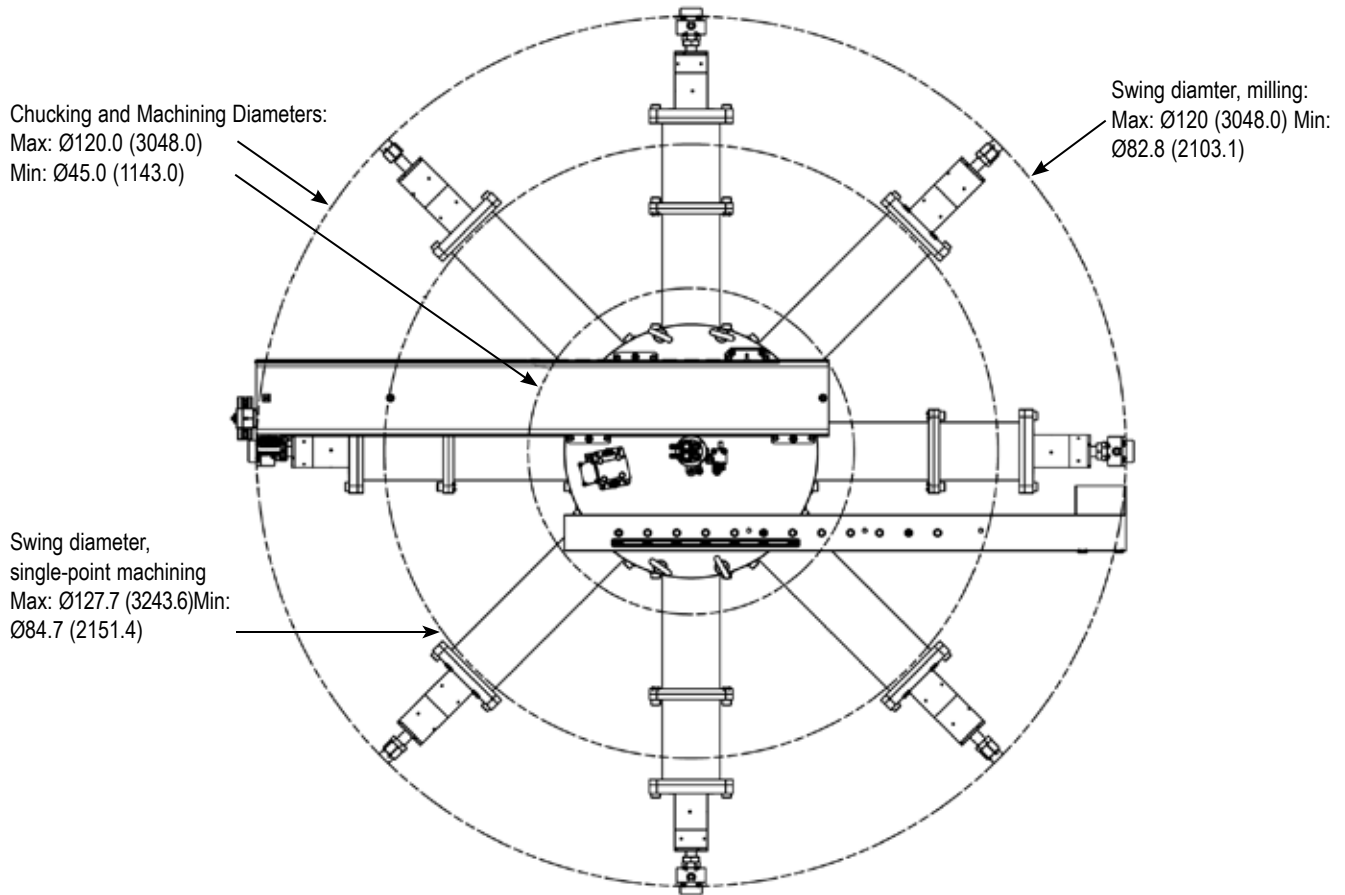

Dim A (all ± 0.25 (6.4):

Max. clearance with tool head fully retracted

Turning arm, single point mach only:	1.76 (44.7)
Milling & turning arm (either milling or single point machining)	1.74 (44.2)
Milling & turning arm, grinding:	1.64 (41.7)

12.13 ± 0.25 (308.1 ± 6.4)
minimum bore depth

NOTE: ± 0.25 (± 6.4) is travel of leveling foot

OPERATIONAL DIMENSIONS

Dimensions in Inch (mm)

OD Chuck Assembly

Machining Diameter:
Max: Ø120.0 (3048.0)
Min: Ø45.0 (1143.0)

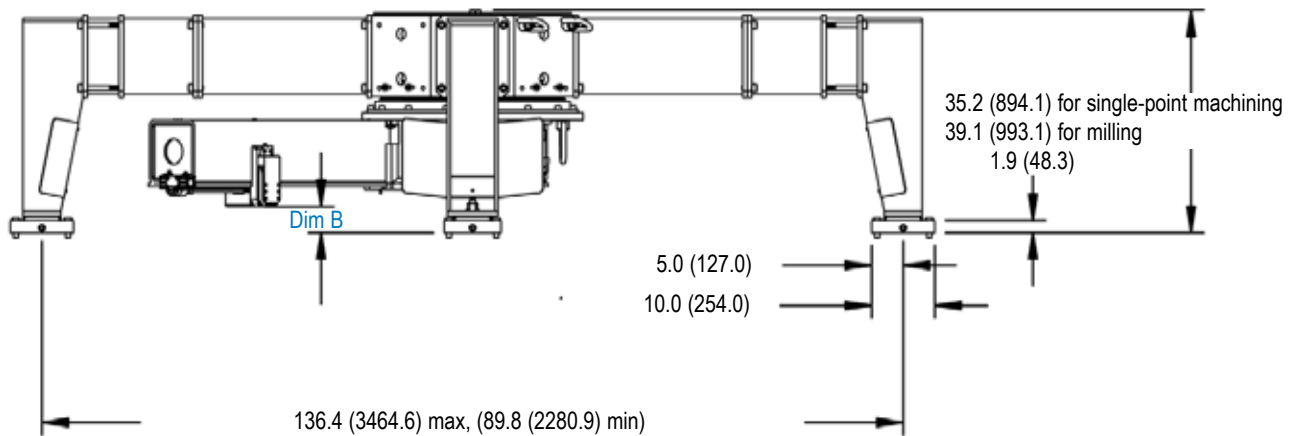
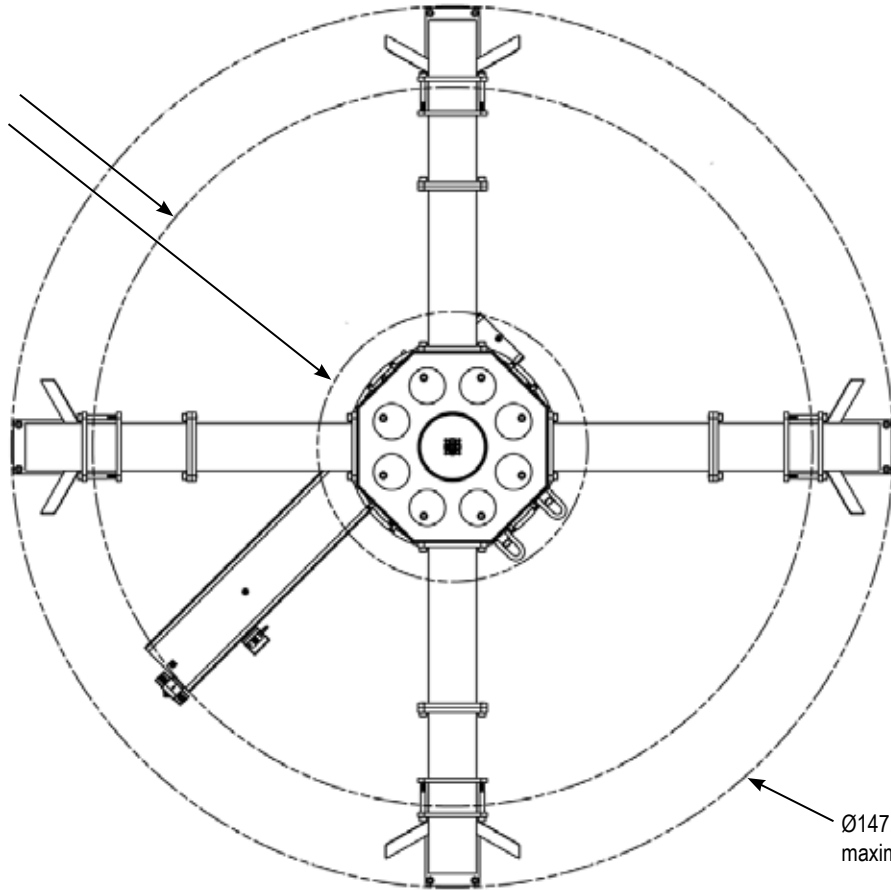

Dim B:

With tool head fully retracted

Turning arm, single point mach only:	4.2 (106.7)
Milling & turning arm: (either milling or single point machining)	4.2 (106.7)
Milling & turning arm, grinding:	4.1 (104.1)

OPERATIONAL DIMENSIONS

Milling Head Assembly

Dimensions in Inch (mm)

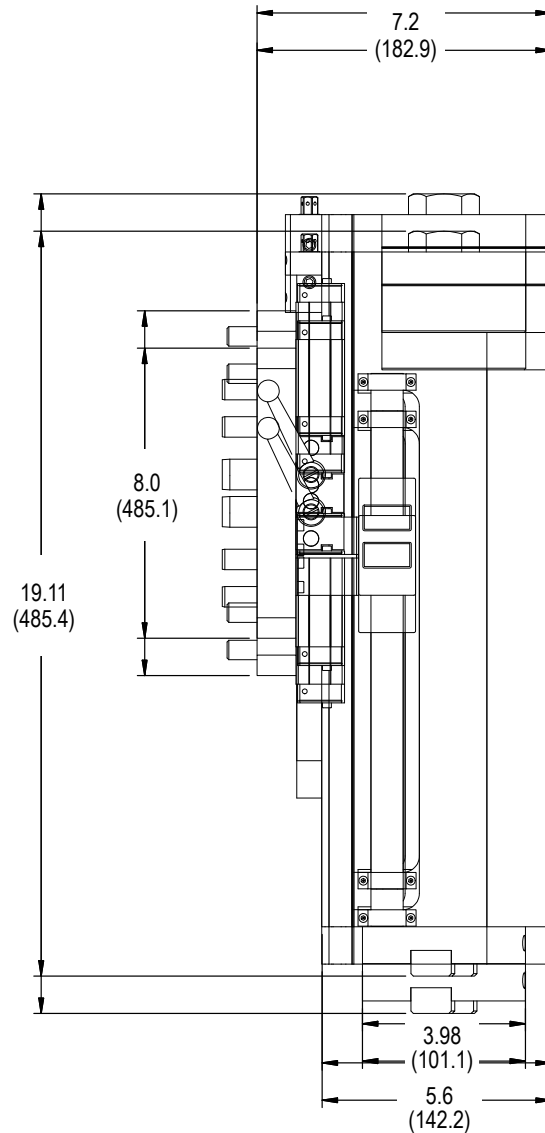

Overall Machine View

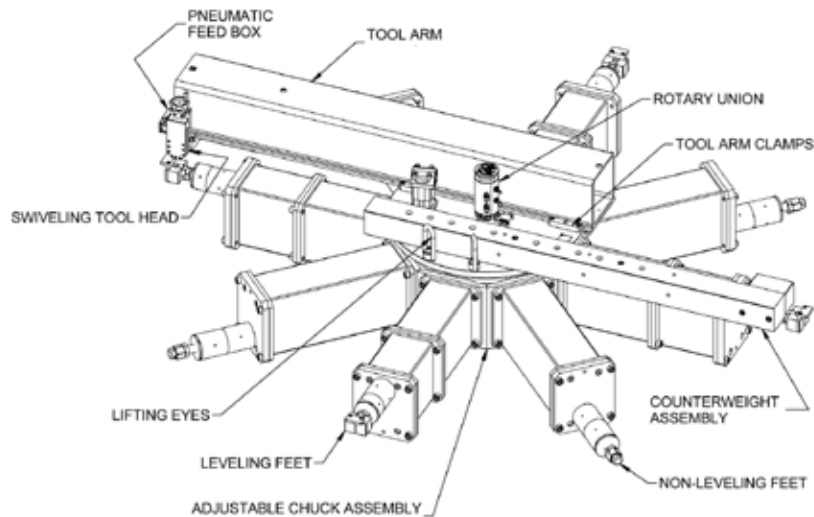

CLIMAX GLOBAL LEARNING CENTER

Climax has been teaching the fundamentals and fine points of portable machine tool operation for practically as long as we've been inventing and building the tools.

At the Global Learning Center situated in our corporate headquarters near Portland, Oregon, we provide training for machine tool operators on portable machine tool safety and machine setup and operation. Trainees also receive technical tips and tools to improve operational efficiencies, with the vast majority of every program devoted to hands-on activities and skill development.

The Climax instructional team includes specialists in shipbuilding, power generation, civil engineering, bridge re-building, petrochemical and other industries.



Whether it's a regularly scheduled course at the Global Learning Center, or custom curriculum conducted at your facility, your machinists will benefit from courses developed by some of the most respected authorities in the business.

Call us today to register for a regularly scheduled class, or talk to us about how we can customize a training program for your specialized application.

Call Climax for:

On-site Training

Need some refresher courses in setting up and operating your Climax machine tool?

Special Projects

Climax has been solving complicated on-site machining and welding problems for our customers since 1964.

Rentals

Even worldwide rental depot locations, you can always rent a Climax portable machine tool from a Climax portable machine tool.

Climax Global Locations

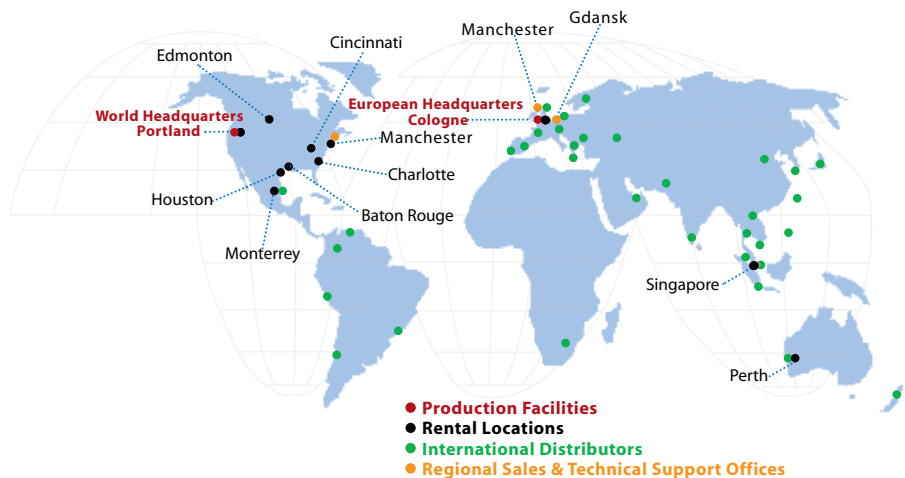

Connect with us:  

World Headquarters

2712 E. Second Street
Newberg, Oregon 97132 USA
Worldwide Telephone: 1.503.538.2185
N. America Toll-Free: 1.800.333.8311
Fax: 1.503.538.7600
Email: info@cpmt.com

European Headquarters

Am Langen Graben 8
52353 Düren, Germany
Telephone: (+49) (0) 2421.9177.0
Fax: (+49) (0) 2421.9177.29
Email: info@cpmt.de