

RSL-Series Low-Profile Hexagon Torque Wrenches **ENERPAC**

▼ RSL Drive Units with interchangeable RLP Hexagon Cassette and RSQ Square Drive Head



Setting New Standards in Safety, Simplicity and Performance

Safety and Performance

- Innovative design that completely encloses all moving parts and minimizes pinch points
- 30-35° rotation angle provides added productivity while avoiding "tool lock-on" which is common with some torque wrench designs

Simplicity

- Simple robust alloy steel design with just three moving parts for reduced maintenance
- Robust handles are available for both sides and the tops of cassettes to allow for extra maneuverability
- Designed to give optimum strength-to-weight and torque-to-weight ratios
- Minimum nose radius for trouble-free tool fit

Versatility

- Interchangeable cassette design
- Wide range of hexagon sizes available for all applications
- Reaction arm has a simple dial lock for rapid change
- For use in multiple industrial, energy, and oil and gas applications

Accuracy

- Accuracy of +/-3%



Options and Accessories

Optional extended reaction arms and tubes are common accessories available for maximum versatility. Please contact your Enerpac representative to help you select the optimum solution for your application.

Page: **269**



Back-Up Spanner

To be used to stop back nut from turning during make up or break out. Two hex sizes in one tool.

Hexagon Sizes (A/F)		Back-Up Spanner Model Number
(in)	(mm)	
1 ¹ / ₁₆ - 1 ¹ / ₄	27 - 32	BUS01
1 ⁷ / ₁₆ - 1 ⁵ / ₈	36 - 41	BUS02
1 ¹³ / ₁₆ - 2	46 - 50	BUS03
2 ³ / ₁₆ - 2 ³ / ₈	55 - 60	BUS04
2 ⁹ / ₁₆ - 2 ³ / ₄	65 - 70	BUS05
2 ¹⁵ / ₁₆ - 3 ¹ / ₈	75 - 80	BUS06
3 ¹ / ₂ - 3 ⁷ / ₈	-	BUS07
4 ¹ / ₄ - 4 ⁵ / ₈	-	BUS08
-	85 - 90	BUS09
3 ³ / ₄ - 3 ¹⁵ / ₁₆	95 - 100	BUS10
4 ¹ / ₈ - 4 ¹⁵ / ₁₆	105 - 110	BUS11
-	115 - 120	BUS12

245



Torque Wrench Pumps

Visit enerpac.com for system-matched air and electric torque wrench pumps that are ideal for use with hydraulic torque wrenches.

Page: **291**

Drive Units for Hexagon Cassettes & Square Drive Heads



One Drive, Two Tools

One RSL-Hydraulic Drive Unit fits RLP-Hexagon Cassette or RSQ-Square Drive Head.

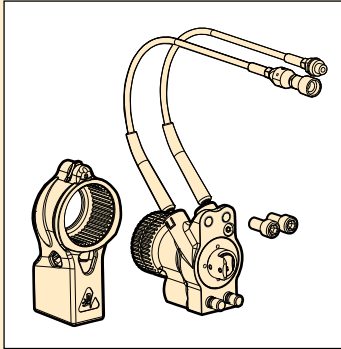

RSL

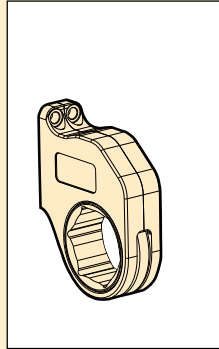

RLP... / RLP...SL

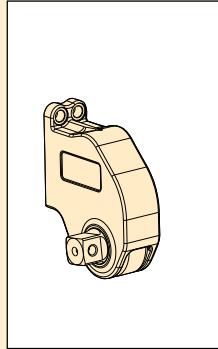

RSQ

▼ RSL Torque Wrench Drive Unit shown with RLP Low-Profile Hexagon Cassette

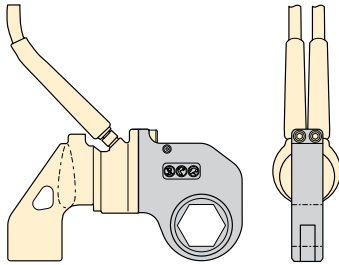

▼ Contact Enerpac for optional handles.

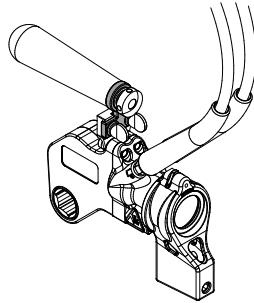

▼ RSL Torque Wrench Drive Unit shown with RSQ Square Drive Head

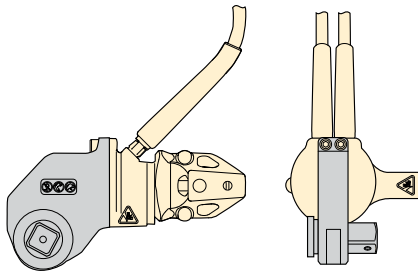

▼ Contact Enerpac for optional handles.

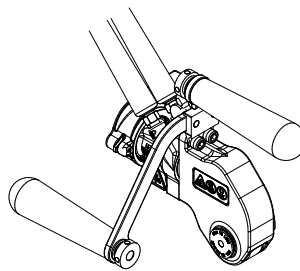

▼ SELECTION CHART

Hexagon Cassette Range (A/F) (see pages 264-268 for sizes and model numbers)		Drive Unit Model Number	Maximum Torque Output		Weight (lbs)
(in)	(mm)		(ft-lbs)	(Nm)	
7/8 - 2 3/8	26 - 60	RSL1500	1408	1909	3.4
1 5/16 - 2 15/16	33 - 75	RSL3000	3080	4176	5.6
1 11/16 - 3 1/8	46 - 80	RSL5000	5303	7190	8.9
2 3/8 - 3 3/8	60 - 80	RSL8000	7862	10659	10.6
2 7/16 - 4 5/8	62 - 110	RSL11000	11,154	15123	11.6
2 15/16 - 4 3/8	75 - 115	RSL19000	18,843	25547	20.0
3 1/8 - 6 1/8	80 - 155	RSL28000	28,002	37965	22.0

RSL Series



Maximum Torque Output:

1408 - 28,002 Ft-lbs

Hexagon Range:

7/8 - 6 1/8 inches

Hexagon Range:

26 - 155 mm

Maximum Operating Pressure:

10,000 psi



Select the Right Torque

250%

Choose your Enerpac Torque Wrench using the untightening rule of thumb: Loosening torque equals about 250% of tightening torque.



Torque Wrench Hoses

Use Enerpac THQ700 Series hoses with RSL-Series torque wrenches to ensure the integrity of your hydraulic system.

6 feet long, 2 hoses	THQ702T
19.5 feet long, 2 hoses	THQ706T
39 feet long, 2 hoses	THQ712T



RLP-Series, Low-Profile Hexagon Cassettes

For metric and imperial hexagon cassettes see pages 264-268.

Page: **264**



RSQ-Series, Square-Drive Heads

RSQ Square Drive Heads are interchangeable with the RLP Hexagon Cassettes for the same size RSL Drive Unit.

Page: **272**

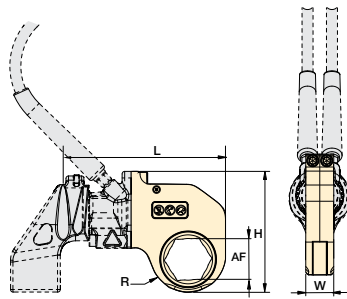

Hexagon Range:
7/8 - 6 1/8 inches

Hexagon Range:
26 - 155 mm

Maximum Operating Pressure:
10,000 psi

**RSL
Series**



▼ **SELECTION CHART**

Drive Unit Model Number	AF Size		Hexagon Cassette Model Number	Maximum Torque Output		Dimensions (in)				Wt. (lbs)	Dimensions (mm)				Wt. (kg)
	(in)	(mm)		(ft-lbs)	(Nm)	R	L	W	H		R	L	W	H	
RSL1500	7/8	-	RLP1014	320	434	0.79	6.00	1.25	4.33	2.2	20,1	152,4	31,8	110,0	1,0
	1 1/16	26	RLP1101	640	868	0.95	6.05	1.25	4.50	2.2	24,1	153,7	31,8	114,3	1,0
	1 1/8	-	RLP1102	640	868	1.03	6.12	1.25	4.57	2.3	26,2	155,4	31,8	116,1	1,0
	1 3/16	30	RLP1103	640	868	1.03	6.12	1.25	4.57	2.3	26,2	155,4	31,8	116,1	1,0
	1 1/4	32	RLP1104	640	868	1.03	6.12	1.25	4.57	2.3	26,2	155,4	31,8	116,1	1,0
	1 5/16	33	RLP1105	900	1220	1.15	6.24	1.25	4.69	2.4	29,2	158,5	31,8	119,1	1,1
	1 3/8	35	RLP1106	900	1220	1.15	6.24	1.25	4.69	2.4	29,2	158,5	31,8	119,1	1,1
	1 7/16	36	RLP1107	900	1220	1.15	6.24	1.25	4.69	2.4	29,2	158,5	31,8	119,1	1,1
	1 1/2	38	RLP1108	1408	1909	1.31	6.41	1.25	4.86	2.7	33,3	162,8	31,8	123,4	1,2
	1 9/16	-	RLP1109	1408	1909	1.31	6.41	1.25	4.86	2.7	33,3	162,8	31,8	123,4	1,2
	1 5/8	41	RLP1110	1408	1909	1.31	6.41	1.25	4.86	2.7	33,3	162,8	31,8	123,4	1,2
	1 11/16	-	RLP1111	1408	1909	1.40	6.49	1.25	4.94	2.7	35,6	164,8	31,8	125,5	1,2
	1 3/4	-	RLP1112	1408	1909	1.40	6.49	1.25	4.94	2.7	35,6	164,8	31,8	125,5	1,2
	1 13/16	46	RLP1113	1408	1909	1.40	6.49	1.25	4.94	2.7	35,6	164,8	31,8	125,5	1,2
	1 7/8	-	RLP1114	1408	1909	1.48	6.58	1.25	5.03	2.7	37,6	167,1	31,8	127,8	1,2
	1 15/16	-	RLP1115	1408	1909	1.48	6.58	1.25	5.03	2.7	37,6	167,1	31,8	127,8	1,2
	2	50	RLP1200	1408	1909	1.48	6.58	1.25	5.03	2.7	37,6	167,1	31,8	127,8	1,2
	2 1/16	-	RLP1201	1408	1909	1.58	6.68	1.25	5.13	2.7	40,1	169,7	31,8	130,3	1,2
	2 1/8	-	RLP1202	1408	1909	1.58	6.68	1.25	5.13	2.7	40,1	169,7	31,8	130,3	1,2
	2 3/16	55	RLP1203	1408	1909	1.58	6.68	1.25	5.13	2.7	40,1	169,7	31,8	130,3	1,2
2 1/4	-	RLP1204	1408	1909	1.70	6.79	1.25	5.24	2.8	43,2	172,5	31,8	133,1	1,3	
2 5/16	-	RLP1205	1408	1909	1.70	6.79	1.25	5.24	2.8	43,2	172,5	31,8	133,1	1,3	
2 3/8	60	RLP1206	1408	1909	1.70	6.79	1.25	5.24	2.8	43,2	172,5	31,8	133,1	1,3	
RSL3000	1 5/16	33	RLP3105	900	1220	1.18	7.62	1.38	5.49	3.5	30,0	193,5	35,1	139,4	1,6
	1 3/8	35	RLP3106	900	1220	1.18	7.62	1.38	5.49	3.5	30,0	193,5	35,1	139,4	1,6
	1 7/16	36	RLP3107	900	1220	1.18	7.62	1.38	5.49	3.5	30,0	193,5	35,1	139,4	1,6
	1 1/2	38	RLP3108	1200	1627	1.32	7.77	1.38	5.63	3.9	33,5	197,4	35,1	143,0	1,8
	1 9/16	-	RLP3109	1200	1627	1.32	7.77	1.38	5.63	3.9	33,5	197,4	35,1	143,0	1,8
	1 5/8	41	RLP3110	1200	1627	1.32	7.77	1.38	5.63	3.9	33,5	197,4	35,1	143,0	1,8
	1 11/16	-	RLP3111	1900	2576	1.47	7.87	1.38	5.78	4.0	37,3	199,9	35,1	146,8	1,8
	1 3/4	-	RLP3112	1900	2576	1.47	7.87	1.38	5.78	4.0	37,3	199,9	35,1	146,8	1,8
	1 13/16	46	RLP3113	1900	2576	1.47	7.87	1.38	5.78	4.0	37,3	199,9	35,1	146,8	1,8
	1 7/8	-	RLP3114	2600	3526	1.60	8.04	1.38	5.92	4.5	40,6	204,2	35,1	150,4	2,0
	1 15/16	-	RLP3115	2600	3526	1.60	8.04	1.38	5.92	4.5	40,6	204,2	35,1	150,4	2,0
	2	50	RLP3200	2600	3526	1.60	8.04	1.38	5.92	4.5	40,6	204,2	35,1	150,4	2,0
	2 1/16	-	RLP3201	3080	4176	1.76	8.16	1.38	6.08	4.7	44,7	207,3	35,1	154,4	2,1
	2 1/8	-	RLP3202	3080	4176	1.76	8.16	1.38	6.08	4.7	44,7	207,3	35,1	154,4	2,1
	2 3/16	55	RLP3203	3080	4176	1.76	8.16	1.38	6.08	4.7	44,7	207,3	35,1	154,4	2,1
	2 1/4	-	RLP3204	3080	4176	1.84	8.25	1.38	6.15	4.8	46,7	209,6	35,1	156,2	2,2
	2 5/16	-	RLP3205	3080	4176	1.84	8.25	1.38	6.15	4.8	46,7	209,6	35,1	156,2	2,2
	2 3/8	60	RLP3206	3080	4176	1.84	8.25	1.38	6.15	4.8	46,7	209,6	35,1	156,2	2,2
	2 7/16	62	RLP3207	3080	4176	1.95	8.14	1.38	6.26	4.6	49,5	206,8	35,1	159,0	2,1
	2 1/2	63	RLP3208	3080	4176	1.95	8.14	1.38	6.26	4.6	49,5	206,8	35,1	159,0	2,1
	2 9/16	65	RLP3209	3080	4176	1.95	8.14	1.38	6.26	4.6	49,5	206,8	35,1	159,0	2,1
	2 5/8	-	RLP3210	3080	4176	2.04	8.23	1.38	6.36	4.4	51,8	209,0	35,1	161,5	2,0
	2 11/16	-	RLP3211	3080	4176	2.04	8.23	1.38	6.36	4.4	51,8	209,0	35,1	161,5	2,0
	2 3/4	70	RLP3212	3080	4176	2.04	8.23	1.38	6.36	4.4	51,8	209,0	35,1	161,5	2,0
	2 13/16	-	RLP3213	3080	4176	2.16	8.34	1.38	6.54	4.7	54,9	211,8	35,1	166,1	2,1
2 7/8	-	RLP3214	3080	4176	2.16	8.34	1.38	6.54	4.7	54,9	211,8	35,1	166,1	2,1	
2 15/16	75	RLP3215	3080	4176	2.16	8.34	1.38	6.54	4.7	54,9	211,8	35,1	166,1	2,1	

Hexagon Cassettes for RSL-Series



Enerpac's Bolting Integrity Software Solutions play a key role in implementing and managing an Integrity Program for bolted

connections. Our Bolting Software Suite includes **BoltUp** (free, online calculator providing reliable, repeatable bolt loads), **Informate** (bolt load calculation software for huge range of flanged joints and clamped connections), and **Integrity Data Management System/iDMS** (flexible data management and activity-planning system for use on assets featuring bolted connections).

Contact Enerpac for more information.

Page: 416



Slimline Hexagon Cassettes

For accessing narrow spaces RLP...SL Stepped-Width

Hexagon Cassettes are available. Slimline cassettes use same drive unit as standard RLP-cassettes.

270

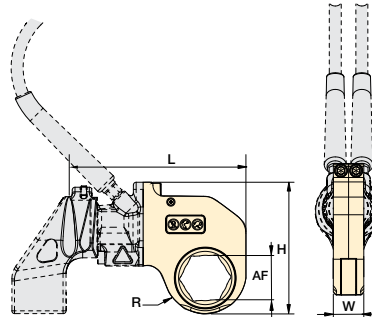

RSL Series



Hexagon Range:

7/8 - 6 1/8 inches

Hexagon Range:

26 - 155 mm

Maximum Operating Pressure:

10,000 psi

▼ SELECTION CHART

Drive Unit Model Number	AF Size		Hexagon Cassette Model Number	Maximum Torque Output		Dimensions (in)				Wt. (lbs)	Dimensions (mm)				Wt. (kg)
	(in)	(mm)		(ft-lbs)	(Nm)	R	L	W	H		R	L	W	H	
RSL5000	1 1/16	-	RLP5111	2600	3526	1.61	9.08	1.75	6.52	6.6	40,9	230,6	44,5	165,6	3,0
	1 3/4	-	RLP5112	2600	3526	1.61	9.08	1.75	6.52	6.6	40,9	230,6	44,5	165,6	3,0
	1 3/16	46	RLP5113	2600	3526	1.61	9.08	1.75	6.52	6.6	40,9	230,6	44,5	165,6	3,0
	1 7/8	-	RLP5114	2600	3526	1.61	9.08	1.75	6.52	6.6	40,9	230,6	44,5	165,6	3,0
	1 5/16	-	RLP5115	2600	3526	1.61	9.08	1.75	6.52	6.6	40,9	230,6	44,5	165,6	3,0
	2	50	RLP5200	2600	3526	1.61	9.08	1.75	6.52	6.6	40,9	230,6	44,5	165,6	3,0
	2 1/16	-	RLP5201	3500	4746	1.71	9.18	1.75	6.62	6.5	43,4	233,2	44,5	168,1	2,9
	2 1/8	-	RLP5202	3500	4746	1.71	9.18	1.75	6.62	6.5	43,4	233,2	44,5	168,1	2,9
	2 3/16	55	RLP5203	3500	4746	1.71	9.18	1.75	6.62	6.5	43,4	233,2	44,5	168,1	2,9
	2 1/4	-	RLP5204	4500	6102	1.87	9.34	1.75	6.78	7.0	47,5	237,2	44,5	172,2	3,2
	2 5/16	-	RLP5205	4500	6102	1.87	9.34	1.75	6.78	7.0	47,5	237,2	44,5	172,2	3,2
	2 3/8	60	RLP5206	4500	6102	1.87	9.34	1.75	6.78	7.0	47,5	237,2	44,5	172,2	3,2
	2 7/16	62	RLP5207	5303	7191	2.01	9.48	1.75	6.92	7.0	51,1	240,8	44,5	175,8	3,2
	2 1/2	63	RLP5208	5303	7191	2.01	9.48	1.75	6.92	7.0	51,1	240,8	44,5	175,8	3,2
	2 9/16	65	RLP5209	5303	7191	2.01	9.48	1.75	6.92	7.0	51,1	240,8	44,5	175,8	3,2
	2 5/8	-	RLP5210	5303	7191	2.16	9.63	1.75	7.07	7.5	54,9	244,6	44,5	179,6	3,4
	2 1 1/16	-	RLP5211	5303	7191	2.16	9.63	1.75	7.07	7.5	54,9	244,6	44,5	179,6	3,4
	2 3/4	70	RLP5212	5303	7191	2.16	9.63	1.75	7.07	7.5	54,9	244,6	44,5	179,6	3,4
	2 13/16	-	RLP5213	5303	7191	2.24	9.71	1.75	7.15	7.5	56,9	246,6	44,5	181,6	3,4
	2 7/8	-	RLP5214	5303	7191	2.24	9.71	1.75	7.15	7.5	56,9	246,6	44,5	181,6	3,4
2 15/16	75	RLP5215	5303	7191	2.24	9.71	1.75	7.15	7.5	56,9	246,6	44,5	181,6	3,4	
3	-	RLP5300	5303	7191	2.26	9.73	1.75	7.17	7.2	57,4	247,1	44,5	182,1	3,3	
3 1/16	-	RLP5301	5303	7191	2.26	9.73	1.75	7.17	7.2	57,4	247,1	44,5	182,1	3,3	
3 1/8	80	RLP5302	5303	7191	2.26	9.73	1.75	7.17	7.2	57,4	247,1	44,5	182,1	3,3	
2 3/8	60	RLP8206	4500	6102	1.87	9.53	2.25	7.00	8.9	47,5	242,1	57,2	177,8	4,0	
2 7/16	62	RLP8207	5800	7865	2.01	9.67	2.25	7.13	9.0	51,1	245,6	57,2	181,1	4,1	
2 1/2	63	RLP8208	5800	7865	2.01	9.67	2.25	7.13	9.0	51,1	245,6	57,2	181,1	4,1	
2 9/16	65	RLP8209	5800	7865	2.01	9.67	2.25	7.13	9.0	51,1	245,6	57,2	181,1	4,1	
2 5/8	-	RLP8210	7862	10.661	2.16	9.82	2.25	7.28	9.6	54,9	249,4	57,2	184,9	4,4	
2 1 1/16	-	RLP8211	7862	10.661	2.16	9.82	2.25	7.28	9.6	54,9	249,4	57,2	184,9	4,4	
2 3/4	70	RLP8212	7862	10.661	2.16	9.82	2.25	7.28	9.6	54,9	249,4	57,2	184,9	4,4	
2 13/16	-	RLP8213	7862	10.661	2.24	9.90	2.25	7.38	9.6	56,9	251,5	57,2	187,5	4,4	
2 7/8	-	RLP8214	7862	10.661	2.24	9.90	2.25	7.38	9.6	56,9	251,5	57,2	187,5	4,4	
2 15/16	75	RLP8215	7862	10.661	2.24	9.90	2.25	7.38	9.6	56,9	251,5	57,2	187,5	4,4	
3	-	RLP8300	7862	10.661	2.26	9.92	2.25	7.39	9.3	57,4	252,0	57,2	187,7	4,2	
3 1/16	-	RLP8301	7862	10.661	2.26	9.92	2.25	7.39	9.3	57,4	252,0	57,2	187,7	4,2	
3 1/8	80	RLP8302	7862	10.661	2.26	9.92	2.25	7.39	9.3	57,4	252,0	57,2	187,7	4,2	

RSL Series



Hexagon Range:

7/8 - 6 1/8 inches

Hexagon Range:

26 - 155 mm

Maximum Operating Pressure:

10,000 psi

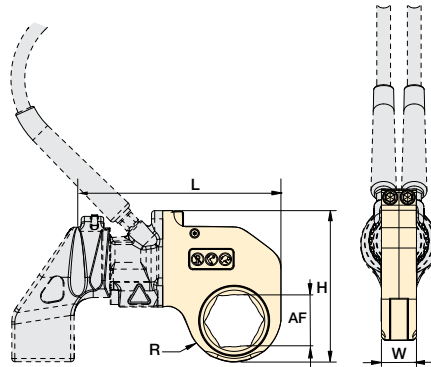

▼ SELECTION CHART

Drive Unit Model Number	AF Size		Hexagon Cassette Model Number	Maximum Torque Output		Dimensions (in)				Wt.	Dimensions (mm)				Wt.
	(in)	(mm)		(ft-lbs)	(Nm)	R	L	W	H	(lbs)	R	L	W	H	(kg)
RSL11000	2 7/16	62	RLP11207	5800	7865	1.98	10.00	2.50	8.03	14.2	50,3	254,0	63,5	204,0	6,4
	2 1/2	-	RLP11208	5800	7865	1.98	10.00	2.50	8.03	14.2	50,3	254,0	63,5	204,0	6,4
	2 9/16	65	RLP11209	5800	7865	1.98	10.00	2.50	8.03	14.2	50,3	254,0	63,5	204,0	6,4
	2 5/8	-	RLP11210	7300	9899	2.19	11.20	2.50	8.23	14.8	55,6	284,5	63,5	209,0	6,7
	2 11/16	-	RLP11211	7300	9899	2.19	11.20	2.50	8.23	14.8	55,6	284,5	63,5	209,0	6,7
	2 3/4	70	RLP11212	7300	9899	2.19	11.20	2.50	8.23	14.8	55,6	284,5	63,5	209,0	6,7
	2 13/16	-	RLP11213	9000	12.204	2.29	11.31	2.50	8.34	14.8	58,2	287,3	63,5	211,8	6,7
	2 7/8	-	RLP11214	9000	12.204	2.29	11.31	2.50	8.34	14.8	58,2	287,3	63,5	211,8	6,7
	2 15/16	75	RLP11215	9000	12.204	2.29	11.31	2.50	8.34	14.8	58,2	287,3	63,5	211,8	6,7
	3	-	RLP11300	11,154	15.125	2.43	11.44	2.50	8.47	15.2	61,7	290,6	63,5	215,1	6,9
	3 1/16	-	RLP11301	11,154	15.125	2.43	11.44	2.50	8.47	15.2	61,7	290,6	63,5	215,1	6,9
	3 1/8	80	RLP11302	11,154	15.125	2.43	11.44	2.50	8.47	15.2	61,7	290,6	63,5	215,1	6,9
	3 3/16	-	RLP11303	11,154	15.125	2.60	11.71	2.50	8.64	16.6	66,0	297,4	63,5	219,5	7,5
	-	85	RLP11085M	11,154	15.125	2.60	11.71	2.50	8.64	16.6	66,0	297,4	63,5	219,5	7,5
	3 1/4	-	RLP11304	11,154	15.125	2.60	11.71	2.50	8.64	16.6	66,0	297,4	63,5	219,5	7,5
	3 5/16	-	RLP11305	11,154	15.125	2.60	11.71	2.50	8.64	16.6	66,0	297,4	63,5	219,5	7,5
	3 3/8	-	RLP11306	11,154	15.125	2.60	11.71	2.50	8.64	16.6	66,0	297,4	63,5	219,5	7,5
	3 7/16	-	RLP11307	11,154	15.125	2.60	11.71	2.50	8.64	16.6	66,0	297,4	63,5	219,5	7,5
	3 1/2	-	RLP11308	11,154	15.125	2.60	11.71	2.50	8.64	16.6	66,0	297,4	63,5	219,5	7,5
	-	90	RLP11090M	11,154	15.125	2.88	11.89	2.50	8.92	17.2	73,2	302,0	63,5	226,6	7,8
	3 9/16	-	RLP11309	11,154	15.125	2.88	11.89	2.50	8.92	17.2	73,2	302,0	63,5	226,6	7,8
	3 5/8	-	RLP11310	11,154	15.125	2.88	11.89	2.50	8.92	17.2	73,2	302,0	63,5	226,6	7,8
	3 11/16	-	RLP11311	11,154	15.125	2.88	11.89	2.50	8.92	17.2	73,2	302,0	63,5	226,6	7,8
	3 3/4	95	RLP11312	11,154	15.125	2.88	11.89	2.50	8.92	17.2	73,2	302,0	63,5	226,6	7,8
	3 13/16	-	RLP11313	11,154	15.125	2.88	11.89	2.50	8.92	17.2	73,2	302,0	63,5	226,6	7,8
	3 7/8	-	RLP11314	11,154	15.125	2.88	11.89	2.50	8.92	17.2	73,2	302,0	63,5	226,6	7,8
	3 15/16	100	RLP11315	11,154	15.125	2.98	12.00	2.50	9.03	16.4	75,7	304,8	63,5	229,4	7,4
	4	-	RLP11400	11,154	15.125	2.98	12.00	2.50	9.03	16.4	75,7	304,8	63,5	229,4	7,4
	4 1/16	-	RLP11401	11,154	15.125	2.98	12.00	2.50	9.03	16.4	75,7	304,8	63,5	229,4	7,4
	4 1/8	105	RLP11402	11,154	15.125	2.98	12.00	2.50	9.03	16.4	75,7	304,8	63,5	229,4	7,4
	4 1/4	-	RLP11404	11,154	15.125	2.98	12.00	2.50	9.03	16.4	75,7	304,8	63,5	229,4	7,4
	4 5/16	110	RLP11405	11,154	15.125	3.25	12.27	2.50	9.30	17.6	82,6	311,7	63,5	236,2	8,0
4 1/2	-	RLP11408	11,154	15.125	3.25	12.27	2.50	9.30	17.6	82,6	311,7	63,5	236,2	8,0	
4 5/8	-	RLP11410	11,154	15.125	3.25	12.27	2.50	9.30	17.6	82,6	311,7	63,5	236,2	8,0	

Hexagon Cassettes for RSL-Series



Enerpac's Bolting Integrity Software Solutions

play a key role in implementing and managing an Integrity Program for bolted connections. Our Bolting Software Suite includes **BoltUp** (free, online calculator providing reliable, repeatable bolt loads), **Informate** (bolt load calculation software for huge range of flanged joints and clamped connections), and **Integrity Data Management System/iDMS** (flexible data management and activity-planning system for use on assets featuring bolted connections).

Contact Enerpac for more information.

Page: 416

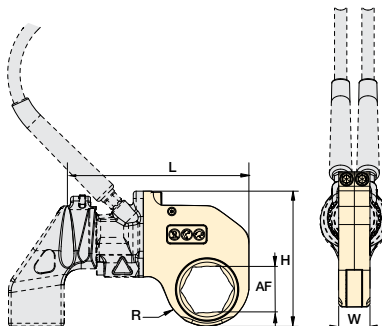

RSL Series



Hexagon Range:
7/8 - 6 1/8 inches

Hexagon Range:
26 - 155 mm

Maximum Operating Pressure:
10,000 psi

▼ SELECTION CHART

Drive Unit Model Number	AF Size		Hexagon Cassette Model Number	Maximum Torque Output		Dimensions (in)				Wt. (lbs)	Dimensions (mm)				Wt. (kg)
	(in)	(mm)		(ft-lbs)	(Nm)	R	L	W	H		R	L	W	H	
RSL19000	2 ¹⁵ / ₁₆	75	RLP19215	11,000	14.916	2.45	12.72	2.75	9.44	21.5	62,2	323,1	69,9	239,8	9,8
	3	-	RLP19300	11,000	14.916	2.45	12.72	2.75	9.44	21.5	62,2	323,1	69,9	239,8	9,8
	3 ¹ / ₁₆	-	RLP19301	11,000	14.916	2.45	12.72	2.75	9.44	21.5	62,2	323,1	69,9	239,8	9,8
	3 ¹ / ₈	80	RLP19302	11,000	14.916	2.45	12.72	2.75	9.44	21.5	62,2	323,1	69,9	239,8	9,8
	3 ³ / ₁₆	-	RLP19303	16,000	21.696	2.77	13.04	2.75	9.76	22.6	70,4	331,2	69,9	247,9	10,3
	-	85	RLP19085M	16,000	21.696	2.77	13.04	2.75	9.76	22.6	70,4	331,2	69,9	247,9	10,3
	3 ¹ / ₄	-	RLP19304	16,000	21.696	2.77	13.04	2.75	9.76	22.6	70,4	331,2	69,9	247,9	10,3
	3 ⁵ / ₁₆	-	RLP19305	16,000	21.696	2.77	13.04	2.75	9.76	22.6	70,4	331,2	69,9	247,9	10,3
	3 ³ / ₈	-	RLP19306	16,000	21.696	2.77	13.04	2.75	9.76	22.6	70,4	331,2	69,9	247,9	10,3
	3 ⁷ / ₁₆	-	RLP19307	16,000	21.696	2.77	13.04	2.75	9.76	22.6	70,4	331,2	69,9	247,9	10,3
	3 ¹ / ₂	-	RLP19308	16,000	21.696	2.77	13.04	2.75	9.76	22.6	70,4	331,2	69,9	247,9	10,3
	-	90	RLP19090M	18,843	25.551	2.95	13.22	2.75	9.94	23.8	74,9	335,8	69,9	252,5	10,8
	3 ⁹ / ₁₆	-	RLP19309	18,843	25.551	2.95	13.22	2.75	9.94	23.8	74,9	335,8	69,9	252,5	10,8
	3 ⁵ / ₈	-	RLP19310	18,843	25.551	2.95	13.22	2.75	9.94	23.8	74,9	335,8	69,9	252,5	10,8
	3 ¹¹ / ₁₆	-	RLP19311	18,843	25.551	2.95	13.22	2.75	9.94	23.8	74,9	335,8	69,9	252,5	10,8
	3 ³ / ₄	95	RLP19312	18,843	25.551	2.95	13.22	2.75	9.94	23.8	74,9	335,8	69,9	252,5	10,8
	3 ¹³ / ₁₆	-	RLP19313	18,843	25.551	2.95	13.22	2.75	9.94	23.8	74,9	335,8	69,9	252,5	10,8
	3 ⁷ / ₈	-	RLP19314	18,843	25.551	2.95	13.22	2.75	9.94	23.8	74,9	335,8	69,9	252,5	10,8
	3 ¹⁵ / ₁₆	100	RLP19315	18,843	25.551	3.30	13.57	2.75	10.28	25.3	83,8	344,7	69,9	261,1	11,5
	4	-	RLP19400	18,843	25.551	3.30	13.57	2.75	10.28	25.3	83,8	344,7	69,9	261,1	11,5
	4 ¹ / ₁₆	-	RLP19401	18,843	25.551	3.30	13.57	2.75	10.28	25.3	83,8	344,7	69,9	261,1	11,5
	4 ¹ / ₈	105	RLP19402	18,843	25.551	3.30	13.57	2.75	10.28	25.3	83,8	344,7	69,9	261,1	11,5
	4 ³ / ₁₆	-	RLP19403	18,843	25.551	3.30	13.57	2.75	10.28	25.3	83,8	344,7	69,9	261,1	11,5
	4 ¹ / ₄	-	RLP19404	18,843	25.551	3.30	13.57	2.75	10.28	25.3	83,8	344,7	69,9	261,1	11,5
	4 ⁵ / ₁₆	110	RLP19405	18,843	25.551	3.44	13.71	2.75	10.43	25.6	87,4	348,2	69,9	264,9	11,6
	4 ³ / ₈	-	RLP19406	18,843	25.551	3.44	13.71	2.75	10.43	25.6	87,4	348,2	69,9	264,9	11,6
	4 ⁷ / ₁₆	-	RLP19407	18,843	25.551	3.44	13.71	2.75	10.43	25.6	87,4	348,2	69,9	264,9	11,6
	4 ¹ / ₂	-	RLP19408	18,843	25.551	3.44	13.71	2.75	10.43	25.6	87,4	348,2	69,9	264,9	11,6
	-	115	RLP19115M	18,843	25.551	3.44	13.71	2.75	10.43	25.6	87,4	348,2	69,9	264,9	11,6
	4 ⁹ / ₁₆	-	RLP19409	18,843	25.551	3.44	13.71	2.75	10.43	25.6	87,4	348,2	69,9	264,9	11,6
4 ⁵ / ₈	-	RLP19410	18,843	25.551	3.44	13.71	2.75	10.43	25.6	87,4	348,2	69,9	264,9	11,6	

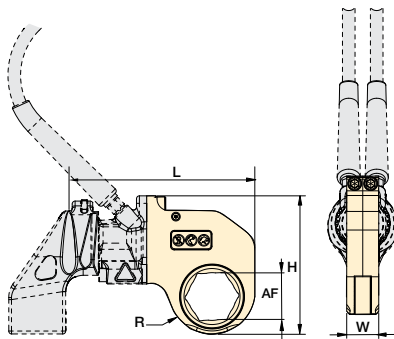

Hexagon Range:
7/8 - 6 1/8 inches

Hexagon Range:
26 - 155 mm

Maximum Operating Pressure:
10,000 psi

RSL Series



▼ SELECTION CHART

Drive Unit Model Number	AF Size		Hexagon Cassette Model Number	Maximum Torque Output		Dimensions (in)				Wt. (lbs)	Dimensions (mm)				Wt. (kg)
	(in)	(mm)		(ft-lbs)	(Nm)	R	L	W	H		R	L	W	H	
RSL28000	3 1/8	80	RLP28302	16,000	21.696	2.56	14.36	3.00	10.54	27.6	65,0	364,7	76,2	267,7	12,5
	3 3/16	-	RLP28303	16,000	21.696	2.56	14.36	3.00	10.54	27.6	65,0	364,7	76,2	267,7	12,5
	-	85	RLP28085M	16,000	21.696	2.56	14.36	3.00	10.54	27.6	65,0	364,7	76,2	267,7	12,5
	3 1/4	-	RLP28304	16,000	21.696	2.56	14.36	3.00	10.54	27.6	65,0	364,7	76,2	267,7	12,5
	3 5/16	-	RLP28305	16,000	21.696	2.56	14.36	3.00	10.54	27.6	65,0	364,7	76,2	267,7	12,5
	3 3/8	-	RLP28306	16,000	21.696	2.56	14.36	3.00	10.54	27.6	65,0	364,7	76,2	267,7	12,5
	3 7/16	-	RLP28307	16,000	21.696	2.56	14.36	3.00	10.54	27.6	65,0	364,7	76,2	267,7	12,5
	3 1/2	-	RLP28308	16,000	21.696	2.56	14.36	3.00	10.54	27.6	65,0	364,7	76,2	267,7	12,5
	-	90	RLP28090M	22,000	29.832	2.92	14.36	3.00	10.77	28.8	74,2	364,7	76,2	273,6	13,1
	3 9/16	-	RLP28309	22,000	29.832	2.92	14.36	3.00	10.77	28.8	74,2	364,7	76,2	273,6	13,1
	3 5/8	-	RLP28310	22,000	29.832	2.92	14.36	3.00	10.77	28.8	74,2	364,7	76,2	273,6	13,1
	3 11/16	-	RLP28311	22,000	29.832	2.92	14.36	3.00	10.77	28.8	74,2	364,7	76,2	273,6	13,1
	3 3/4	95	RLP28312	22,000	29.832	2.92	14.36	3.00	10.77	28.8	74,2	364,7	76,2	273,6	13,1
	3 13/16	-	RLP28313	22,000	29.832	2.92	14.36	3.00	10.77	28.8	74,2	364,7	76,2	273,6	13,1
	3 7/8	-	RLP28314	22,000	29.832	2.92	14.36	3.00	10.77	28.8	74,2	364,7	76,2	273,6	13,1
	3 15/16	100	RLP28315	28,002	37.971	3.29	14.47	3.00	11.14	31.7	83,6	367,5	76,2	283,0	14,4
	4	-	RLP28400	28,002	37.971	3.29	14.47	3.00	11.14	31.7	83,6	367,5	76,2	283,0	14,4
	4 1/16	-	RLP28401	28,002	37.971	3.29	14.47	3.00	11.14	31.7	83,6	367,5	76,2	283,0	14,4
	4 1/8	105	RLP28402	28,002	37.971	3.29	14.47	3.00	11.14	31.7	83,6	367,5	76,2	283,0	14,4
	4 3/16	-	RLP28403	28,002	37.971	3.29	14.47	3.00	11.14	31.7	83,6	367,5	76,2	283,0	14,4
	4 1/4	-	RLP28404	28,002	37.971	3.29	14.47	3.00	11.14	31.7	83,6	367,5	76,2	283,0	14,4
	4 5/16	110	RLP28405	28,002	37.971	3.43	14.61	3.00	11.28	31.5	87,1	371,1	76,2	286,5	14,3
	4 3/8	-	RLP28406	28,002	37.971	3.43	14.61	3.00	11.28	31.5	87,1	371,1	76,2	286,5	14,3
	4 7/16	-	RLP28407	28,002	37.971	3.43	14.61	3.00	11.28	31.5	87,1	371,1	76,2	286,5	14,3
	4 1/2	-	RLP28408	28,002	37.971	3.43	14.61	3.00	11.28	31.5	87,1	371,1	76,2	286,5	14,3
	-	115	RLP28115M	28,002	37.971	3.43	14.61	3.00	11.28	31.5	87,1	371,1	76,2	286,5	14,3
	4 9/16	-	RLP28409	28,002	37.971	3.43	14.61	3.00	11.28	31.5	87,1	371,1	76,2	286,5	14,3
	4 5/8	-	RLP28410	28,002	37.971	3.43	14.61	3.00	11.28	31.5	87,1	371,1	76,2	286,5	14,3
	4 3/4	120	RLP28412	28,002	37.971	3.65	14.83	3.00	11.50	33.5	92,7	376,7	76,2	292,1	15,2
	-	123	RLP28123M	28,002	37.971	3.65	14.83	3.00	11.50	33.5	92,7	376,7	76,2	292,1	15,2
	4 7/8	-	RLP28414	28,002	37.971	3.65	14.83	3.00	11.50	33.5	92,7	376,7	76,2	292,1	15,2
	5	-	RLP28500	28,002	37.971	3.65	14.83	3.00	11.50	33.5	92,7	376,7	76,2	292,1	15,2
	5 1/8	130	RLP28502	28,002	37.971	3.79	14.97	3.00	11.64	33.2	96,3	380,2	76,2	295,7	15,1
	5 3/16	-	RLP28503	28,002	37.971	3.79	14.97	3.00	11.64	33.2	96,3	380,2	76,2	295,7	15,1
	5 1/4	-	RLP28504	28,002	37.971	3.79	14.97	3.00	11.64	33.2	96,3	380,2	76,2	295,7	15,1
	5 5/8	135	RLP28506	28,002	37.971	3.79	14.97	3.00	11.64	33.2	96,3	380,2	76,2	295,7	15,1
	5 1/2	140	RLP28508	28,002	37.971	4.05	15.23	3.00	11.90	33.5	102,9	386,8	76,2	302,3	15,2
	5 9/16	-	RLP28509	28,002	37.971	4.05	15.23	3.00	11.90	33.5	102,9	386,8	76,2	302,3	15,2
	5 3/8	-	RLP28510	28,002	37.971	4.05	15.23	3.00	11.90	33.5	102,9	386,8	76,2	302,3	15,2
	5 3/4	145	RLP28512	28,002	37.971	4.05	15.23	3.00	11.90	33.5	102,9	386,8	76,2	302,3	15,2
5 7/8	150	RLP28514	28,002	37.971	4.22	15.48	3.00	12.15	34.5	107,2	393,2	76,2	308,6	15,6	
6	-	RLP28600	28,002	37.971	4.22	15.48	3.00	12.15	34.5	107,2	393,2	76,2	308,6	15,6	
6 1/8	155	RLP28602	28,002	37.971	4.22	15.48	3.00	12.15	34.5	107,2	393,2	76,2	308,6	15,6	

▼ TWMP503



TWMP503, Torque Wrench Moly Paste

- Enerpac 503 Moly Paste reduces friction on threaded fasteners – bolts, nuts and studs
- The low and uniform friction coefficient of 0.06 (torque coefficient, K, of 0.11) creates reliable assembly conditions
- This lubricant stays in place through heat, load and vibration to ensure trouble-free disassembly from -20° F to 750° F (-29° C to 400° C)
- 4 lbs. (1,8 kg) container

for
RSL Series



ERA-Series, Extended Reaction Arms

For Torque Wrench Model No.	Model Number	Dimensions (in)					(lbs)
		A	B	C	D	E	
RSL1500	ERA15114	3.42	5.71	7.68	1.14	1.42	1.98
	ERA15228	4.45	7.13	9.06	1.14	1.42	3.97
	ERA15342	5.47	8.90	10.87	1.14	1.42	5.95
	ERA15456	6.46	9.29	11.26	1.14	1.42	7.94
RSL3000	ERA15570	7.44	11.30	13.27	1.14	1.42	9.92
	ERA30114	4.13	7.68	10.12	1.34	1.61	5.95
	ERA30228	5.16	9.09	11.54	1.34	1.61	7.94
	ERA30342	6.14	10.47	12.91	1.34	1.61	9.92
RSL5000	ERA30456	7.13	11.89	14.66	1.34	1.61	11.90
	ERA50114	5.16	8.19	11.18	1.73	1.89	9.04
	ERA50228	6.14	9.57	12.60	1.73	1.89	11.02
	ERA50342	7.13	10.98	13.98	1.73	1.89	13.01
RSL11000	ERA50456	8.15	12.37	15.39	1.73	1.89	15.00
	ERA110114	4.92	8.62	11.65	2.01	2.32	13.89
	ERA110228	5.91	10.04	13.06	2.01	2.32	16.09
	ERA110342	6.93	11.46	14.45	2.01	2.32	18.08
RSL28000	ERA110456	7.91	12.83	15.83	2.01	2.32	20.06
	ERA280228	6.73	13.19	16.18	2.24	3.50	24.91
	ERA280342	7.76	14.57	17.60	2.24	3.50	30.00

- Only to be used on RSL-drive units with RSQ-square drive wrenches
- Used in place of standard reaction arm
- Lightweight interchangeable design
- Full torque rated

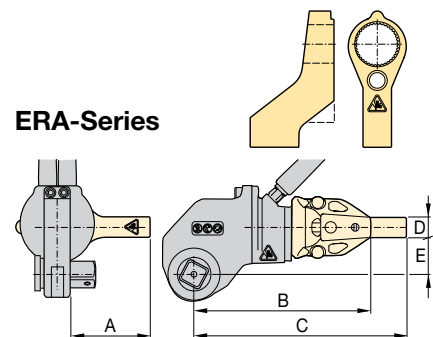

NOTE: Extended Reaction Arms for RSL8000 and RSL19000 are available on request.

ERT-Series, Extended Reaction Tubes

For Torque Wrench Model No.	Model Number	Dimensions (in)			Wt. (lbs)
		A	B	Ø C	
RSL1500	ERT152	6.18	2.01	2.24	1.98
	ERT156	10.20	5.98	2.24	3.53
	ERT159	13.19	9.02	2.24	5.51
	ERT1512	16.18	12.01	2.24	7.50
	ERT1524	28.19	24.02	2.24	14.78
RSL3000	ERT3012	16.89	12.01	2.76	6.61
	ERT3024	28.90	24.02	2.76	13.01
RSL5000	ERT5012	17.76	12.01	3.50	12.35
	ERT5024	29.76	24.02	3.50	24.91
RSL11000	ERT1106	12.99	5.98	3.74	4.63
	ERT11012	19.02	12.01	3.74	9.04
	ERT11018	25.00	17.99	3.74	13.45
	ERT11024	30.98	24.02	3.74	18.52
RSL19000	ERT19024	31.50	24.02	5	36.82
RSL28000	ERT2806	13.82	5.98	5	7.94
	ERT28012	19.80	12.01	5	16.09
	ERT28018	25.79	17.99	5	24.03
	ERT28024	31.81	24.02	5	36.60

- Only to be used on RSL-drive units with RLP-hexagon cassettes
- Used in place of standard reaction arm
- One-piece steel design, durable and simple
- Increases tool fit in restricted access areas
- Full torque rated

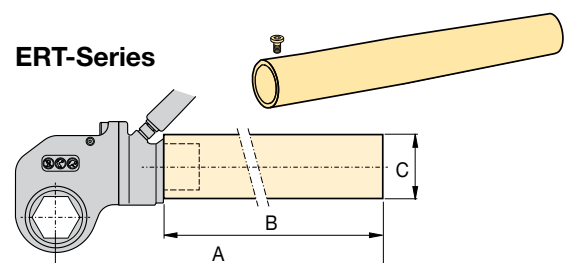

NOTE: Extended Reaction Tubes for RSL8000 are available on request.

▼ Shown: RSL drive unit with interchangeable RLP—SL slimline cassette



Setting New Standards in Simplicity, Versatility and Accuracy



Torque Wrench Pumps

Visit enerpac.com for system matched air and electric torque wrench pumps that are ideal for use with hydraulic torque wrenches.

Page: 291



Options and Accessories

Optional extended reaction arms and tubes are common accessories available for maximum versatility. Please contact your Enerpac representative to help you select the optimum solution for your application.

Page: 269



Back-Up Spanner

To be used to stop back nut from turning during make up or break out. Two hex sizes in one tool.

Hexagon Sizes (A/F)		Back-Up Spanner Model Number
(in)	(mm)	
1 ¹ / ₁₆ - 1 ¹ / ₄	27 - 32	BUS01
1 ⁷ / ₁₆ - 1 ⁵ / ₈	36 - 41	BUS02
1 ¹³ / ₁₆ - 2	46 - 50	BUS03
2 ³ / ₁₆ - 2 ³ / ₈	55 - 60	BUS04
2 ⁹ / ₁₆ - 2 ³ / ₄	65 - 70	BUS05
2 ¹⁵ / ₁₆ - 3 ¹ / ₈	75 - 80	BUS06
3 ¹ / ₂ - 3 ⁷ / ₈	-	BUS07
4 ¹ / ₄ - 4 ⁵ / ₈	-	BUS08
-	85 - 90	BUS09
3 ³ / ₄ - 3 ¹⁵ / ₁₆	95 - 100	BUS10
4 ¹ / ₈ - 4 ¹⁵ / ₁₆	105 - 110	BUS11
-	115 - 120	BUS12

Page: 245

Simplicity

- Minimum nose radius for trouble-free tool fit which makes it uniquely equipped to access tight spaces, such as Blowout Preventers (BOPs)
- Simple robust alloy steel design with three moving parts for reduced maintenance
- Proven to perform even in the harshest environments
- Reaction arm has a simple dial lock for rapid change
- Designed to give optimum strength-to-weight and torque-to-weight ratios

Versatility

- Interchangeable cassette design
- Drive unit / hexagon cassette combination for limited height in line solutions
- Wide range of hexagon sizes available for all applications

Accuracy

- Accuracy of +/-3%

Ease of Use

- Few moving parts are easily accessible for quick field maintenance
- Innovative design that completely encloses all moving parts and minimizes pinch points

Slimline Stepped-Width Hexagon Cassettes



Slimline Stepped-Width Hexagon Cassettes

Accessing narrow spaces, typically found on BOP stacks, normally requires significantly reducing the width of the torque wrench. For the tool operator, this has always meant vastly reduced tool durability, and/or reduced torque output.

By using the highest-grade materials and perfecting the geometry, the RSL Slimline cassettes are able to provide greater torque, get into tighter spaces, and vastly outperform the competition in product durability.

RSL Series



Hexagon Range:

1 1/4 - 3 3/16 inches

Hexagon Range:

32 - 80 mm

Maximum Operating Pressure:

10,000 psi

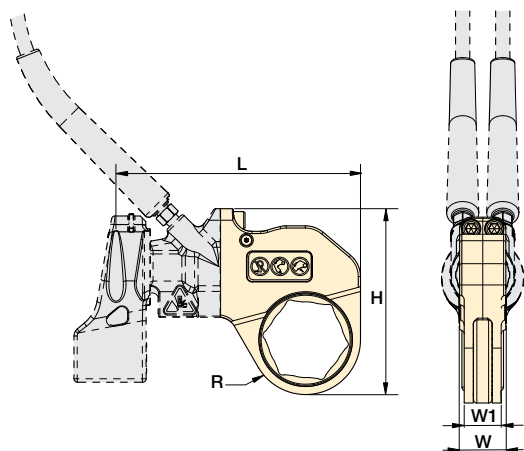

Select the Right Torque

Choose your Enerpac Torque Wrench using the untightening rule of thumb: Loosening torque equals about 250% of tightening torque.

▼ SELECTION CHART

Drive Unit Model Number	AF Size		Hexagon Cassette Model Number	Maximum Torque Output		Dimensions (in)					Wt. (lbs)	Dimensions (mm)					Wt. (kg)
	(in)	(mm)		(ft-lbs)	(Nm)	R	L	W	W1	H		R	L	W	W1	H	
RSL1500	1 1/4	32	RLP1104SL	375	509	1.03	6.12	1.25	1.00	4.57	2.2	26,2	155,4	31,8	25,4	116,1	1,0
	1 7/16	36	RLP1107SL	658	892	1.15	6.24	1.25	1.00	4.69	2.3	29,2	158,5	31,8	25,4	119,1	1,0
	1 5/8	41	RLP1110SL	831	1127	1.31	6.41	1.25	1.00	4.86	2.7	33,3	162,8	31,8	25,4	123,4	1,2
	1 13/16	46	RLP1113SL	831	1127	1.40	6.49	1.25	1.00	4.94	2.7	35,6	164,8	31,8	25,4	125,5	1,2
	2	50	RLP1200SL	831	1127	1.48	6.58	1.25	1.00	5.03	2.7	37,6	167,1	31,8	25,4	127,8	1,2
RSL3000	2	50	RLP3200SL	1354	1836	1.60	8.04	1.38	1.13	5.92	4.5	40,6	204,2	35,1	28,7	150,4	2,0
	2 3/16	55	RLP3203SL	1604	2175	1.76	8.16	1.38	1.13	6.08	4.7	44,7	207,3	35,1	28,7	154,4	2,1
	2 3/8	60	RLP3206SL	1604	2175	1.84	8.25	1.38	1.13	6.15	4.8	46,7	209,6	35,1	28,7	156,2	2,2
	2 9/16	65	RLP3209SL	1604	2175	1.95	8.14	1.38	1.13	6.26	4.6	49,5	206,8	35,1	28,7	159,0	2,1
	2 3/4	70	RLP3212SL	1604	2175	2.04	8.23	1.38	1.13	6.36	4.4	51,8	209,0	35,1	28,7	161,5	2,0
	2 15/16	75	RLP3215SL	1604	2175	2.16	8.34	1.38	1.13	6.54	4.7	54,9	211,8	35,1	28,7	166,1	2,1
RSL5000	2 3/4	70	RLP5212SL	4173	5659	2.16	9.63	1.75	1.62	7.07	7.5	54,9	244,6	44,5	41,1	179,6	3,4
	3 1/8	80	RLP5302SL	4173	5659	2.26	9.73	1.75	1.62	7.17	7.2	57,4	247,1	44,5	41,1	182,1	3,3
RSL8000	2 3/16	55	RLP8203SL	2487	3372	1.71	9.53	2.25	2.00	6.84	8.5	43,4	242,1	57,2	50,8	173,7	3,9
	2 3/8	60	RLP8206SL	3198	4336	1.87	9.67	2.25	2.00	7.00	8.9	47,5	245,6	57,2	50,8	177,8	4,0
	2 9/16	65	RLP8209SL	4122	5589	2.01	9.67	2.25	2.00	7.13	9.0	51,1	245,6	57,2	50,8	181,1	4,1
	2 3/4	70	RLP8212SL	5587	7576	2.16	9.82	2.25	2.00	7.28	9.6	54,9	249,4	57,2	50,8	184,9	4,4
	2 15/16	75	RLP8215SL	5587	7576	2.24	9.90	2.25	2.00	7.36	9.6	56,9	251,5	57,2	50,8	186,9	4,4
	3 1/8	80	RLP8302SL	5587	7576	2.26	9.92	2.25	2.00	7.39	9.3	57,4	252,0	57,2	50,8	187,7	4,2
3 3/16	-	RLP8303SL	4740	6427	2.26	9.92	2.25	2.00	7.39	9.3	57,4	252,0	57,2	50,8	187,7	4,2	

▼ RSL drive unit with interchangeable RSQ square drive cassette



Setting New Standards in Safety, Simplicity and Performance



Torque Wrench Options and Accessories

Optional accessories are available for maximum versatility. Please contact your Enerpac representative to help you select the optimum solution for your application.



Select the Right Torque

Choose your Enerpac Torque Wrench using the untightening rule of thumb: Loosening torque equals about 250% of tightening torque.

Page: 412



BSH-Series Sockets

Heavy-Duty Impact Sockets for power driven torquing equipment.

Page: 244



Back-Up Spanners

Hands free tool to be used to stop back nut from turning during make up or break out.

Page: 245



Torque Wrench Hoses

Series hoses with RSL-Series torque wrenches to ensure the integrity of your hydraulic system.

6 feet long, 2 hoses	THQ702T
19.5 feet long, 2 hoses	THQ706T
39 feet long, 2 hoses	THQ712T

Safety and Performance

- Innovative design that completely encloses all moving parts and minimizes pinch points
- 30–35° of operating stroke provides added productivity while avoiding “tool lock on” which is common with some torque wrench designs

Simplicity

- Simple robust design with just three moving parts for reduced maintenance
- Robust handles are available which mount on both sides and the tops of cassettes to allow for extra maneuverability
- Pull-type square drive release for quickly reversing the square drive for tightening or loosening

Versatility

- Square Drive Sets available with interchangeable Hexagon Cassettes
- Power head / square drive combination for flexible use with standard impact quality sockets
- Reaction arm has a simple dial lock for rapid change

Accuracy

- Accuracy of +/-3%

RSL-Series, Square Drive Torque Wrenches

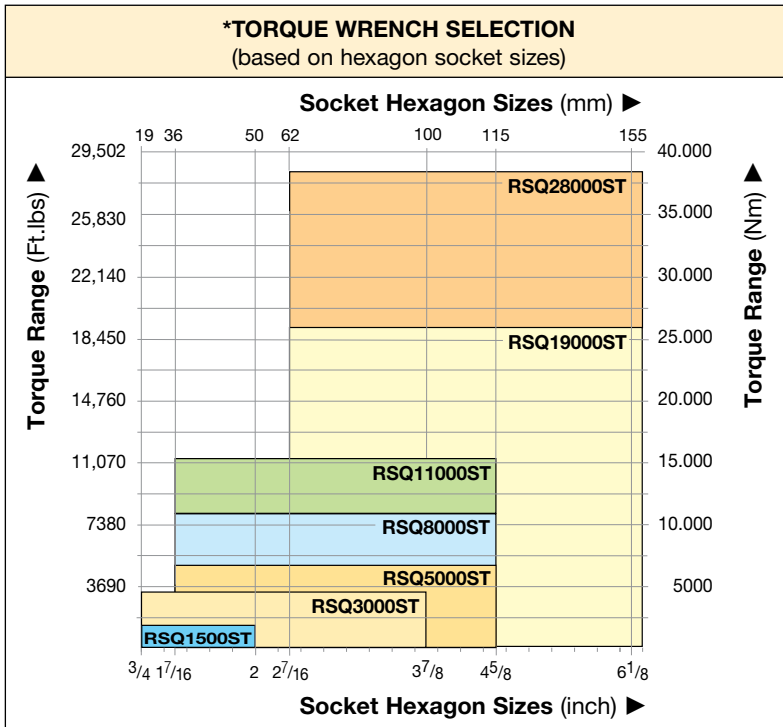

See page 244 for BSH-Sockets.

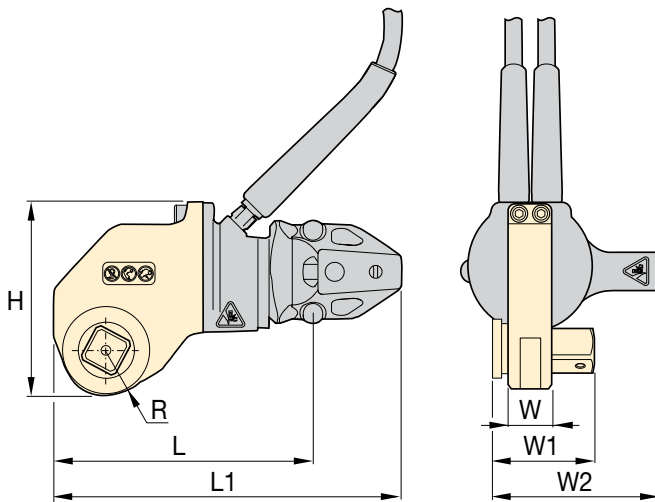

SELECTION CHART

Maximum Torque Output		Square Drive Size (in)	Square Drive Head Model Numbers ¹⁾	Square Drive Torque Wrench Set Model Numbers ²⁾	Dimensions (in)							Weight (lbs)		
(ft.-lbs)	(Nm)				W	W1	W2	H	L	L1	R	Drive Unit (no reaction arm)	Reaction Arm	Square Drive Head
1408	1909	3/4	RSQ1500	RSQ1500ST	1.25	2.30	3.98	4.48	6.29	7.45	0.94	3.4	1.0	2.8
3080	4176	1	RSQ3000	RSQ3000ST	1.50	2.88	4.89	5.57	7.67	10.30	1.25	5.6	2.2	5.2
5303	7190	1 1/2	RSQ5000	RSQ5000ST	1.75	3.71	6.31	6.42	9.27	11.67	1.52	8.9	4.0	9.1
7862	10659	1 1/2	RSQ8000	RSQ8000ST	2.40	4.14	6.30	6.65	9.47	11.78	1.52	10.6	4.3	11.6
11154	15123	1 1/2	RSQ11000	RSQ11000ST	2.50	4.63	6.70	7.93	11.20	12.40	1.88	11.6	6.6	18.4
18843	25547	2 1/2	RSQ19000	RSQ19000ST	3.25	6.38	10.42	9.48	13.46	18.97	2.50	20.0	15.7	28.9
28002	37965	2 1/2	RSQ28000	RSQ28000ST	3.50	6.54	8.93	10.35	14.09	21.07	2.50	22.0	11.1	39.3

¹⁾ When ordering an RSL Square Drive Head the RSL Drive Unit must be ordered separately.

²⁾ An RSQ....ST Torque Wrench Set includes a RSL Square Drive Head, RSL Drive Unit with short Whip Hoses, and Reaction Arm

RSL Series



Maximum Torque Output:

1408 - 28,002 ft.lbs

Maximum Torque Output:

1909 - 37,965 Nm

Square Drive Range:

3/4 - 2 1/2 inches

Maximum Operating Pressure:

10,000 psi



Safe T™ Torque Lock

The Safe T Torque Lock is suitable for all bolted applications from 140 ft-lbs to 11,070 ft-lbs. using a heavy-duty impact socket.

The patented mechanical locking system creates a hands-free torque wrench solution suitable for Enerpac only square drive tools.

Suitable for:

RSQ3000
RSQ5000
RSQ11000

Page: 246



Torque Wrench Pumps

Visit enerpac.com for system matched air and electric torque wrench pumps that are ideal for use with hydraulic torque wrenches.

Page: 291