

**SMALL DIAMETER
 BEVELER**



DESCRIPTION

E.H. Wachs SDB206/2 is a strong and versatile handheld beveling and prepping machine that delivers maximum power and performance for fast and accurate end preps. The SDB 206 operates on pipe and tube from 2.27" through 6.77" ID, up to 0.75" wall (57mm through 172 mm ID, up to 19.05 mm wall). Machines OD up to 7" (177.8mm) with standard mandrel and up to 9.63" (244.6mm) with optional Large ID Accessory Kit

The SDB 206/2 will face, bevel, deburr, compound bevel and counterbore simultaneously on carbon, stainless and high alloy steels and will also machine boiler tube, heavy wall pipe, and thin wall stainless tubing. The SDB offers versatility, durability, and a compact and lightweight design, and can be fitted to difficult to prep elbows with the optional 56-414-01 fitting mandrel.

**MACHINE DESIGN CAPABILITIES
 AND DURABILITY**

- Machines most materials including high alloy and stainless
- Face, bevel, deburr, compound bevel, J-prep and counter bore with the premium high-speed replaceable steel form tools, carbide and high-speed steel insert tooling
- Large bearing load diameter and tapered roller bearings support special heat treated ring and pinion gears for smooth operation and long life of the machine
- Tough, yet lightweight cast aluminum alloy housings for easy handling and performance
- Corrosion and wear resistant finish applied to external components for protection against the elements

FEATURES AND BENEFITS

- Available with pneumatic, hydraulic, and electric drive options
- Maximized rigidity – large diameter mandrel shafts and wide surface chuck legs
- Large diameter mandrels and increased area load bearing surface areas create a rigid powerful tool to perform precision bevels on heavy wall pipe applications
- Easily operate handgrip speed control and precision feed hand wheel
- Will machine up to 9.63" (244.6mm) OD with optional Large ID Accessory Kit
- Minimal clearance required
- Convertible to FF series with optional Flange Facing Kit
- Machine raised groove or smooth 63 RMS finish on flanges with optional FF Kit

**FAST AND EASY SET-UP
 AND OPERATION**

- In less than 5 minutes with quick-change legs
- Automatically center with 3-leg chuck
- Install tool bits in seconds
- Safely operate with the "fail-safe" on-off motor valve
- Compact and lightweight design

**NEW
 IMPROVED
 MANDREL PERFORMANCE**

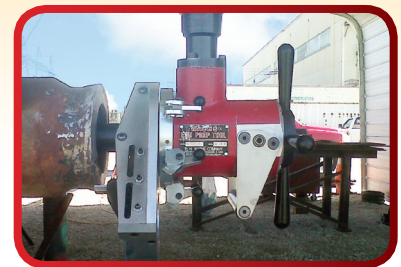

Wachs SDB 206/2 single pointing heavy wall pipe

PRODUCT DIMENSIONS

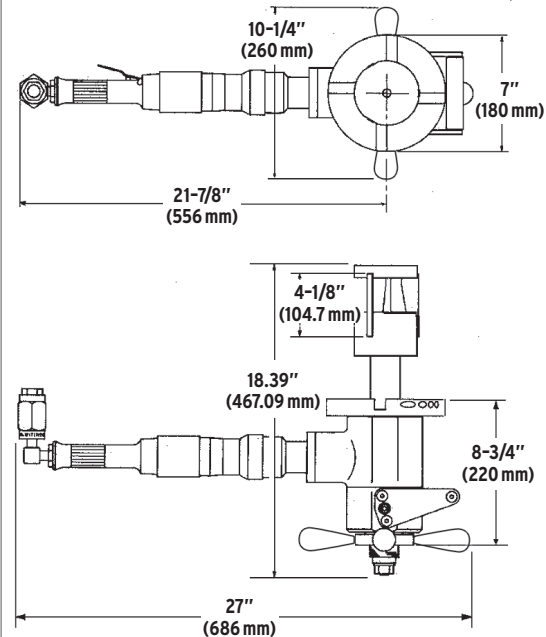

SMALL DIAMETER BEVELER

STANDARD EQUIPMENT

- Rugged, job site friendly storage case
- Standard mandrel
- Complete extension leg set
- Operating tools
- Owners Manual

OPTIONAL EQUIPMENT

- Small mandrel for 1.91" ID through 2.46" ID (48.51 mm ID through 62.48 mm ID)
- Extended range kits for 6.71" ID through 9.04" ID (170.43mm - 229.66mm)
- Optional Flange Facing Kit
- Short perch independent fitting mandrel
- Electric drive motor
- Rotating tool holders expand low range and high range prepping capabilities
- Air filtration to eliminate water and airborne particles
- Available custom tooling

SDB 206 MANDREL UPGRADE KIT FEATURES AND BENEFITS

- Hardened steel chuck body
- Enhanced chuck legs are more durable for superior operation
- New design clamping drawbar
- Thicker extension legs
- Captivated hardware

SERVICES AVAILABLE

- Re-sharpening service with 24-hour turn around
- Rental options for short-term needs

PART NUMBERS

- Pneumatic Powered 56-000-01
- Electric Powered 56-000-02
- Hydraulic Powered 56-000-03
- Mandrel Upgrade Kit 56-310-00
- Fitting Mandrel 56-414-01
- Flange Facing Kit 56-421-00



Fitting Mandrel (optional)



Mandrel with Chuck Legs

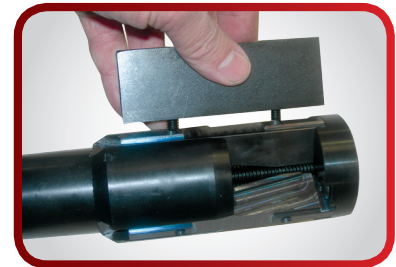

Extension Leg Detail

SPECIFICATIONS

MOUNTING RANGE Standard Mandrel 2.27"-6.77" (57.66mm - 171.96mm)
 Optional Small ID Mandrel Accessory [56-402-01] 1.91"-2.46" (48.5mm - 62.48mm)
 Optional Large ID Mandrel Kit [56-407-02] 6.71"-9.04" (170.43mm - 229.66mm)

PIPE WALL THICKNESS Up to 0.75" (19.05 mm)

CONTROLS Manual feed with index gauge for measurement
 On/off fail-safe motor lever
 Motor speed control

FEED RATE 0.08" (2.12 mm) per revolution

FEED STROKE 2.5" (63.5 mm) usable feed travel

DRIVE OPTIONS Pneumatic 70 cfm @ 90 psi (33 l/s @ 6.2 bar)
 Hydraulic 8 gpm @ 1500 psi (30 lpm @ 103 bar)
 Electric (110 V or 220 V)

TOOL RPM 0 to 40

TOOLING Standard or high-range tool holder with high-speed steel inserts; carbide available

TOOL SLOTS 4 (all rotating head options)

DIMENSIONS Length: 9" without mandrel; 19" with mandrel
 (228.6 mm without mandrel; 482.6 mm with mandrel)
 Width: 11.5" (292.1 mm)
 Height: 27.5" with air motor (698.5 mm with air motor)

WEIGHT 42 lb with mandrel and air motor (19.05 kg)

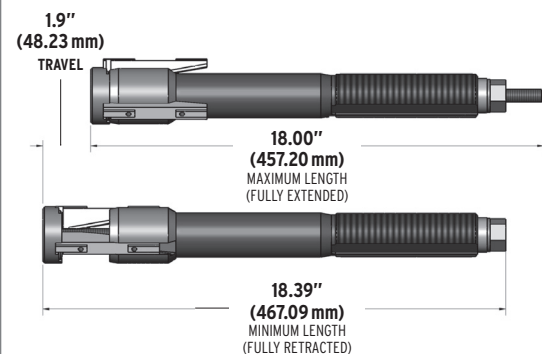

CONTACT US FOR A DEMO OR QUOTE

E-mail: info@ehwachs.com

Telephone: +1.847.537.8800

Fax: +1.847.520.1147

Visit our website: ehwachs.com

Worldwide Headquarters
 600 Knightsbridge Parkway
 Lincolnshire, Illinois 60069