



E.H. WACHS

Superior Equipment. Complete Support.

Small Diameter Split Frame

SDSF

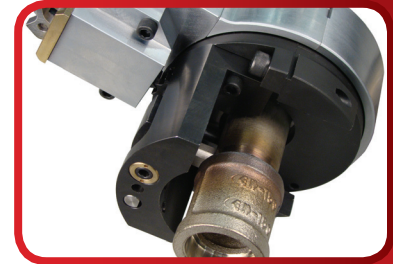
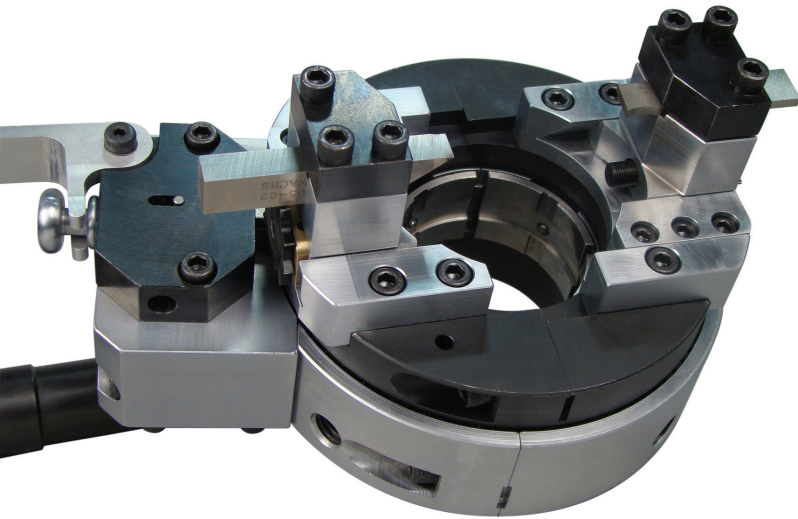

Axial slide for socket weld removal

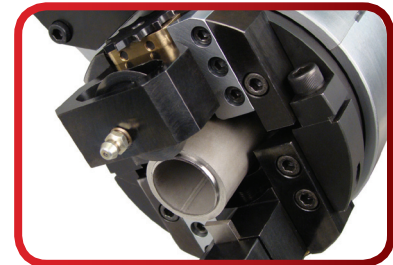

Wheel Cutting Module for FME cutting

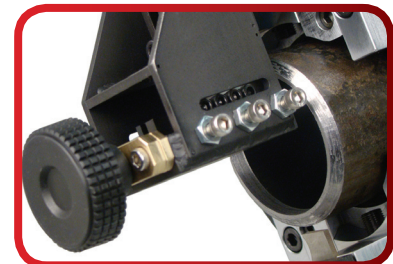

Counterbore attachment fits all models - Mounts securely to tool slide

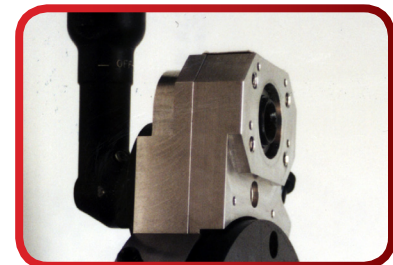

Double drive pinion housing

DESCRIPTION

The Small Diameter Split Frame (SDSF) is an externally mounted machine tool for cutting, beveling, and counterboring pipe from 0.84" to 4.5" diameter. The SDSF is also capable of performing socket weld removal and chipless wheel cutting. Lightweight and flexible, the SDSF is optimized for low-clearance environments. It offers simple setup and operation, featuring a self-squaring clamping system for precise cutting results typically available only with fixed machine tools.

The SDSF operates on air or electric power using standard Wachs motors and adapters. A variety of tool slides and other accessories are interchangeable with all SDSF models. Best of all, the SDSF features E.H. Wachs' legendary durability, designed and built for years of reliable service.

SMALL DIAMETER SPLIT FRAME FEATURES

- Built to withstand greater loads than our already rugged LCSF line
- Machine quickly splits to mount around Outside Diameter of in-line pipe.

- Cuts and bevels pipe up to 7/16" wall including carbon steel and its alloys, Hastelloy™, Inconel™ and other exotic materials.
- Self-squaring pipe clamping system, using either collets or integrated, close tolerance legs with wide feet stability.
- Feed system offers low clearance operation with precise feed for controlled cutting.
- Low friction adjustable bearing system provides maximum stability and extended machine life.
- Fully enclosed bearing and drive gear system for operational safety.
- Infinite motor positioning.
- Modular tool slides.
- Lever type trip actuation for safety.
- Spring loaded axial trip for crash resistance.
- Improved radial trip geometry for crash resistance and durability.
- Improved bearing adjustment design.
- Improved durability in pinion gear bearing arrangement.
- Easier assembly and disassembly of frame halves.
- Improved sealing for chip exclusion.
- Improved collet spring design.
- Captive fasteners used for all accessories.
- Reduced fastener count for simplified inventory. Only 3 hex wrench sizes required to operate machine.
- All 2" through 4" machines can mount using collets or clamp feet.

E.H. WACHS

600 Knightsbridge Pkwy. • Lincolnshire, Illinois 60069 • 800.323.8185 • +1.847.537.8800 worldwide • +1.847.520.1147 fax

www.ehwachs.com



E.H.WACHS

Superior Equipment. Complete Support.

Small Diameter Split Frame

SDSF

SPECIFICATIONS

System Function: Part off, bevel and counterbore pipe & tube; radial and axial socket weld removal; wheel cutting

System Capacity: Machine all tube and pipe from .840" O.D. to 4.5" O.D. (21.3-114.3 mm)-nominal 0.5"-4" pipe .062" to .4375" (1.6 mm-11.1 mm) wall thickness

Cutting Tool Surface Speed: 30 Surface feet per minute, 2" 40sf/m 4"

Drive Options: Pneumatic or electric

Air Requirements: 35 cubic feet per minute @ 90 PSI (1.0 cubic meters per minute @ 6.2 Bar)

Electrical Requirements: 110 Volt - 10amp

Feed Method: Star wheel

Feed Rate: Fixed @ .0031" per trip

Construction: Alloysteel

Tool Slide: Radial or axial feed, cut and bevel, Counterbore, FME module

Tool Stroke: .468" (11.9 mm)

Finish: Hard chrome coating

Tooling: Axial or radial socket weld removal tooling, cut/bevel tooling-High speed steel or carbide

Packaging: Heavy duty carrying case

STANDARD EQUIPMENT

- Self squaring mounting system
- Pinion housing
- Heavy duty watertight carrying case
- Operating hand tools
- Operating manuals

OPTIONAL EQUIPMENT

- Electric drive
- Tooling
- Axial feed tool slide
- Radial feed tool slide set
- Bench mount
- Front drive pinion housing
- Counterbore attachment
- FME tool slide
- Aluminum collet sets
- Clamp pads sets
- Radial socket weld slide

OPTIONAL INTERCHANGEABLE TOOL SLIDES

Modular design allows the operator to convert tool slides in seconds.

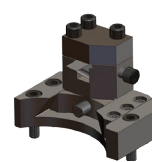

Beveling Tool Slide



Parting Tool Slide

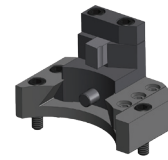

Radial Socket Weld Slide

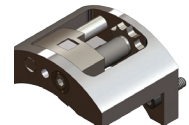

Axial Tool Slide

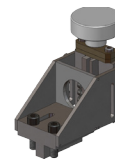

Universal Counterbore Tool Slide

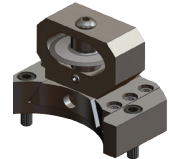

FME Module

RADIAL AND AXIAL CLEARANCE CHART

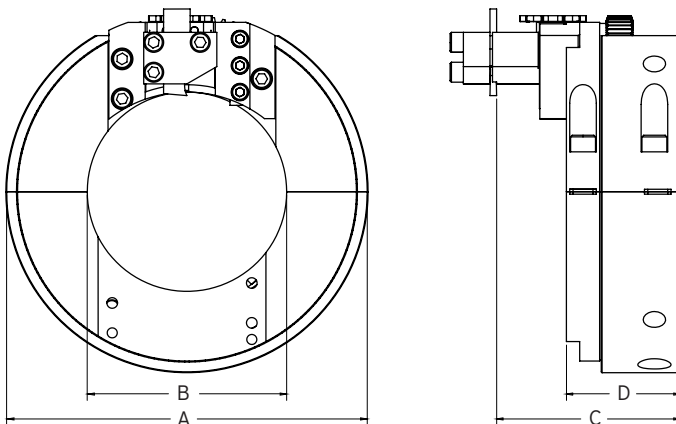

MACHINE SIZE	PIPE DIA. RANGES	DIM A MACHINE O.D.	DIM B MAHINE I.D.	DIM C PARTING LINE	DIM D MACHINE THICKNESS
1"	1/2" - 1"	5.00	1.562	3.468	2.530
2"	1-1/4" - 2"	5.688	2.626	3.468	2.155
3"	2" - 3"	6.871	3.750	3.468	2.155
4"	3" - 4"	7.812	4.750	3.468	2.155

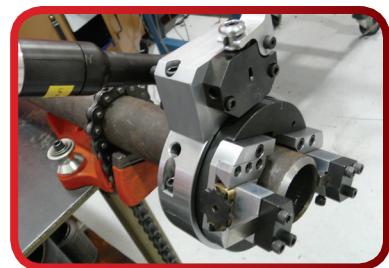

CONTACT US FOR A DEMONSTRATION OR QUOTATION

E-mail: sales@ehwachs.com

Telephone: [+1.847.537.8800](tel:+18475378800)

Fax: [+1.847.520.1147](tel:+18475201147)

Visit our website: www.ehwachs.com