

## HYDRAULIC NUTS

Boltight's hydraulic nuts are available in various types in a wide range of sizes. Typically they range from M24 to M250 but all nuts are made to order so manufacturing custom nuts to suit the application is commonplace.

### DESCRIPTION

A hydraulic nut incorporates its own internal hydraulic jack which enables large diameter bolts to be tensioned to high and accurate pre-loads. They are quick to install using a hydraulic pump which activates the internal jacking system. The effort required to tighten a very large diameter bolt is reduced to the effort needed to operate the pump and if an air or electrically driven pump is used the tightening process is even quicker.

As there is no nut rotation during tightening a hydraulic nut the operation can be performed in a confined space and torsional stresses or thread damage are eliminated.

### HOW THEY WORK

The nut develops a load directly proportional to the oil pressure, this can be accurately controlled and because it is developed hydraulically it is evenly applied.

Multiple nuts can be connected with hoses for simultaneous operation allowing all bolts in a joint to be evenly loaded to the same high and accurate pre-load.

When oil pressure is applied, the joint is compressed and the bolt stretches, this produces a gap between the body of the nut and the piston. Depending on the type of nut, either shims are inserted into the gap or a locking collar on the piston is turned. When the hydraulic pressure is released the load is transferred onto the shims or the locking collar to retain the load.

The hydraulic nut is self aligning while under pressure and misalignment or flange rotation will produce a variation in the gap between the nut body and the piston.



### BENEFITS

- Even and accurate pre load
- No flogging hammers or spanners required
- Single or multiple tightening operation
- Ideal for confined spaces
- Self aligning (shim type)
- Low loss of initial load (shim type)
- Thread damage eliminated

In the case of shim type nuts, tapered shims can be made and fitted to eliminate the effects of misalignment and flange rotation. In the case of collar type nuts, a spherical washer would need to be fitted under the hydraulic nut.

Achieving a bolt pre-load which is in excess of the working load and eliminating bending and torsional stresses greatly improves the fatigue performance of the bolt.

The internal jacking system is not under any pressure when the nut installation is complete and so does not deteriorate when the nut is in service providing it is not exposed to high radiation doses or elevated temperatures.

# PRODUCT INFORMATION

## SPECIFICATION

- Maximum load is generated at operating pressure of 1500 - 2500 bar (21,750 - 36,250 psi) depending on nut type.
- Any threadform can be machined - specify when ordering.
- Nuts can be designed to match and develop the same loads as customers existing nuts.
- Service temperature -20 degrees C to +80 degrees C. Temperature is limited by seals.
- For shim nut - one set of shims are supplied with each nut - specify thickness when ordering.
- Due to continuous development specifications may change without notice.

## OPTIONS AVAILABLE

- Plain Bore.
- Hexagon instead of or in addition to tommy bar holes.
- Side entry for hydraulics instead of or in addition to top entry.
- Single or multiple hydraulic connections.
- Additional Shims.
- 3mm shim gap and shims at zero, to avoid the need for paper thin shims.
- Longer stroke.
- Special threads or threadforms.
- Sizes below M33 (1-1/4") and above M180 (7") are available.

## SHIM TYPE HYDRAULIC NUT

The shim type nut is the most accurate type of hydraulic nut. This nut has a flanged piston. A shim gap is created between the body and the piston when the nut is pressurised. The size of the shim gap is a combination of the compression of the bolted joint and gasket, if fitted, plus the elongation of the bolt.

The nut is pressurised until the hydraulic jack develops the desired pre-load. The shim gap is measured and shims are made to fit. The pressure is increased slightly to allow the shims to be inserted. The pressure is released and the pre-load is transferred onto the shims. A very high percentage of the load is retained in the bolt.

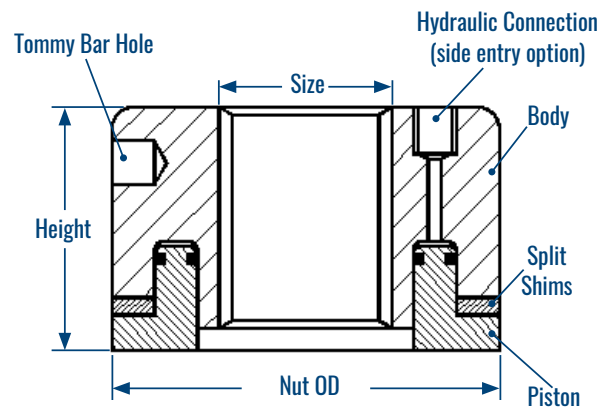

Tool #	Bolt Diameter		Hydraulic Area		Load		Nut OD		Nut Height		Max Shim	
	mm	in	mm	in	kN	tons f	mm	in	mm	in	mm	in
BT-STN-04	M33	1-1/4	1096	1.70	249	25.0	66	2.6	42	1.7	6	0.24
BT-STN-05	M36	1-3/8	1349	2.09	307	30.8	72	2.8	42	1.7	6	0.24
BT-STN-06	M38	1-1/2	1555	2.41	354	35.5	78.5	3.1	42	1.7	6	0.24
BT-STN-07	M42	1-5/8	1885	2.92	429	43.0	86	3.4	42	1.7	6	0.24
BT-STN-08	M45	1-3/4	2095	3.25	477	47.8	91	3.6	45	1.8	6	0.24
BT-STN-09	M48	1-7/8	2475	3.84	563	56.5	98	3.9	48	1.9	9	0.35
BT-STN-10	M52	2	2714	4.21	618	62.0	103	4.1	52	2.0	9	0.35
BT-STN-11	M56	2-1/4	2575	3.99	586	58.8	107	4.2	56	2.2	9	0.35
BT-STN-12	M64	2-1/2	3280	5.08	747	74.9	122	4.8	64	2.5	9	0.35
BT-STN-13	M68	2-3/4	3986	6.18	907	91.0	134	5.3	68	2.7	9	0.35
BT-STN-14	M76	3	4600	7.13	1047	105.0	144	5.7	76	3.0	11	0.43
BT-STN-15	M80	3-1/4	5527	8.57	1258	126.2	158	6.2	80	3.1	11	0.43
BT-STN-16	M90	3-1/2	6298	9.76	1433	143.8	169	6.7	90	3.5	11	0.43
BT-STN-17	M95	3-3/4	7295	11.31	1660	166.6	180	7.1	95	3.7	11	0.43
BT-STN-18	M100	4	8357	12.95	1902	190.8	195	7.7	100	3.9	16	0.63
BT-STN-19	M115	4-1/2	10436	16.18	2375	238.3	216	8.5	115	4.5	16	0.63
BT-STN-20	M125	5	12735	19.74	2899	290.8	241	9.5	125	4.9	16	0.63
BT-STN-21	M140	5-1/2	15601	24.18	3551	356.3	266	10.5	140	5.5	16	0.63
BT-STN-22	M150	6	18400	28.52	4188	420.2	287	11.3	150	5.9	16	0.63

## LOWER COLLAR TYPE HYDRAULIC NUT

This nut has a longer piston which is externally threaded and fitted with a load retaining locking collar. A gap is created between the body and the locking collar when the nut is pressurised. The gap is a combination of the compression of the bolted joint and gasket, if fitted, plus the elongation of the bolt.

The nut is pressurised until the hydraulic jack develops more than the desired pre-load. The locking collar is tightened. The pressure released and the pre-load transferred onto the locking collar threads where settling of the threads causes some of the pre-load to be lost. This is more critical in short bolt applications where the bolt elongation may be small. The pre-load loss on transfer to the collar becomes less significant on longer grip length bolts.

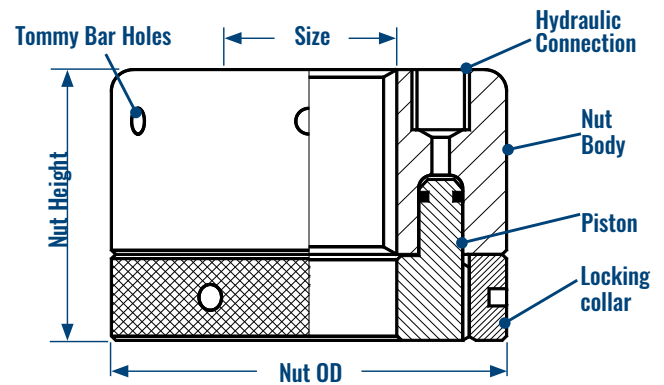

Tool #	Bolt Diameter		Hydraulic Area		Load		Nut OD		Nut Height		Max Stroke	
	mm	in	mm	in	kN	tons f	mm	in	mm	in	mm	in
BT-LCN-04	M33	1-1/4	1096	1.70	249	25.0	66	2.60	55	2.17	6	0.24
BT-LCN-05	M36	1-3/8	1349	2.09	307	30.8	72	2.83	55	2.17	6	0.24
BT-LCN-06	M38	1-1/2	1555	2.41	354	35.5	78.5	3.09	55	2.17	6	0.24
BT-LCN-07	M42	1-5/8	1885	2.92	429	43.0	86	3.39	55	2.17	6	0.24
BT-LCN-08	M45	1-3/4	2095	3.25	477	47.8	91	3.58	55	2.17	6	0.24
BT-LCN-09	M48	1-7/8	2475	3.84	563	56.5	98	3.86	59	2.32	9	0.35
BT-LCN-10	M52	2	2714	4.21	618	62.0	103	4.06	62	2.44	9	0.35
BT-LCN-11	M56	2-1/4	2992	4.63	681	69.4	110	4.33	67	2.64	9	0.35
BT-LCN-12	M64	2-1/2	3280	5.08	747	74.9	122	4.80	77	3.03	9	0.35
BT-LCN-13	M68	2-3/4	3986	6.18	907	91.0	134	5.28	84	3.31	9	0.35
BT-LCN-14	M76	3	4600	7.13	1047	105.0	144	5.67	91	3.58	11	0.43
BT-LCN-15	M80	3-1/4	5527	8.57	1258	126.2	158	6.22	99	3.90	11	0.43
BT-LCN-16	M90	3-1/2	6298	9.76	1433	143.8	169	6.65	107	4.21	11	0.43
BT-LCN-17	M95	3-3/4	7295	11.31	1660	166.6	180	7.09	113	4.45	11	0.43
BT-LCN-18	M100	4	8357	12.95	1902	190.8	195	7.68	122	4.80	16	0.63
BT-LCN-19	M115	4-1/2	10436	16.18	2375	238.3	216	8.50	136	5.35	16	0.63
BT-LCN-20	M125	5	12735	19.74	2899	290.8	241	9.49	151	5.94	16	0.63
BT-LCN-21	M140	5-1/2	15601	24.18	3551	356.3	266	10.47	167	6.57	16	0.63
BT-LCN-22	M150	6	18400	28.52	4188	420.2	287	11.30	181	7.13	16	0.63

# PRODUCT INFORMATION

## UPPER COLLAR "TYPE A" HYDRAULIC NUT

This nut has an internally and externally threaded piston. The external thread is fitted with a load retaining, locking collar. A gap is created between the nut body and the locking collar when pressure is applied. The gap is a combination of the compression of the bolted joint and gasket, if fitted, plus the elongation of the bolt.

The nut is pressurised until the hydraulic jack develops more than the desired pre-load. The locking collar is tightened. The pressure is released and the pre-load is transferred to the locking collar threads. Due to settling of the collar threads some of the pre-load is lost. This is more critical in short bolt applications where the bolt elongation may be small. The pre-load loss on transfer to the collar becomes less significant on long grip length bolts.

The A15 range is designed to give an initial bolt stress of approx 15 tons f/sq inch while the A20 is designed for an initial bolt stress of 20 tons f/sq in with a maximum 1500 bar (21,750 psi) oil pressure. Sizes above M180 (7") can be built to order and larger nuts can be tapped with a smaller thread size to give higher loads for example a 2-1/4" nut with a 2" thread will give an initial load of 59.5 tons, alternatively you can use a hydraulic nut from the A20 range.

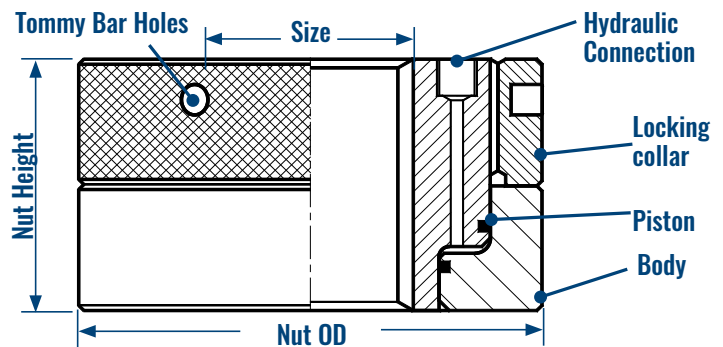

A15 TYPE Tool #	Bolt Diameter		Hydraulic Area		Load		Nut OD		Nut Height		Max Stroke	
	mm	in	mm	in	kN	tons f	mm	in	mm	in	mm	in
UCA15-M522000	M52	2	3301	5.1	495	49.7	110	4.33	70	2.76	9	0.35
UCA15-M562250	M56	2-1/4	3954	6.1	593	59.5	118	4.65	72	2.83	9	0.35
UCA15-M642500	M64	2-1/2	4967	7.7	745	74.8	134	5.28	74	2.91	9	0.35
UCA15-M682750	M68	2-3/4	5994	9.3	899	90.2	145	5.71	74	2.91	9	0.35
UCA15-M763000	M76	3	7046	10.9	1057	106.0	159	6.26	80	3.15	11	0.43
UCA15-M803250	M80	3-1/4	8328	12.9	1249	125.3	171	6.73	84	3.31	11	0.43
UCA15-M903500	M90	3-1/2	9877	15.3	1482	148.7	187	7.36	90	3.54	11	0.43
UCA15-M953750	M95	3-3/4	10967	17.0	1645	165.1	196	7.72	95	3.74	11	0.43
UCA15-M1004000	M100	4	12691	19.7	1904	191.0	212	8.35	103	4.06	16	0.63
UCA15-M1154500	M115	4-1/2	16157	25.0	2424	243.2	234	9.21	115	4.53	16	0.63
UCA15-M1255000	M125	5	19536	30.3	2931	294.0	254	10.00	125	4.92	16	0.63
UCA15-M1405500	M140	5-1/2	23974	37.2	3596	360.8	277	10.91	140	5.51	16	0.63
UCA15-M1506000	M150	6	28452	44.1	4268	428.2	299	11.77	150	5.91	16	0.63
UCA15-M1807000	M180	7	39677	61.5	5952	597.1	350	13.78	170	6.69	16	0.63

A20 TYPE	Bolt Diameter		Hydraulic Area		Load		Nut OD		Nut Height		Max Stroke		
	Tool #	mm	in	mm	in	kN	tons f	mm	in	mm	in	mm	in
<b>UCA20-M331250</b>		M33	1-1/4	1797	2.8	270	27.0	79	3.11	53	2.09	6	0.24
<b>UCA20-M361375</b>		M36	1-3/8	2203	3.4	331	33.2	86	3.39	53	2.09	6	0.24
<b>UCA20-M391500</b>		M39	1-1/2	2512	3.9	377	37.8	91	3.58	55	2.17	6	0.24
<b>UCA20-M421625</b>		M42	1-5/8	2925	4.5	439	44.0	97	3.82	55	2.17	6	0.24
<b>UCA20-M451750</b>		M45	1-3/4	3346	5.2	502	50.4	106	4.17	55	2.17	6	0.24
<b>UCA20-M481875</b>		M48	1-7/8	3534	5.5	530	53.2	110	4.33	70	2.76	8	0.31
<b>UCA20-M522000</b>		M52	2	4536	7.0	680	68.3	120	4.72	72	2.83	8	0.31
<b>UCA20-M562250</b>		M56	2-1/4	5372	8.3	806	80.9	129	5.08	72	2.83	8	0.31
<b>UCA20-M642500</b>		M64	2-1/2	6856	10.6	1028	103.2	147	5.79	74	2.91	9	0.35
<b>UCA20-M682750</b>		M68	2-3/4	7948	12.3	1192	119.6	157	6.18	74	2.91	9	0.35
<b>UCA20-M763000</b>		M76	3	9499	14.7	1425	143.0	173	6.81	80	3.15	11	0.43
<b>UCA20-M803250</b>		M80	3-1/4	11442	17.7	1717	172.2	187	7.36	84	3.31	11	0.43
<b>UCA20-M903500</b>		M90	3-1/2	13383	20.7	2008	201.4	204	8.03	90	3.54	11	0.43
<b>UCA20-M953750</b>		M95	3-3/4	14653	22.7	2198	220.5	213	8.39	95	3.74	11	0.43
<b>UCA20-M1004000</b>		M100	4	17197	26.7	2580	258.8	231	9.09	103	4.06	16	0.63
<b>UCA20-M1154500</b>		M115	4-1/2	21608	33.5	3241	325.2	255	10.04	115	4.53	16	0.63
<b>UCA20-M1255000</b>		M125	5	26389	40.9	3959	397.2	278	10.94	125	4.92	16	0.63
<b>UCA20-M1405500</b>		M140	5-1/2	32002	49.6	4801	481.6	303	11.93	140	5.51	16	0.63
<b>UCA20-M1506000</b>		M150	6	38156	59.1	5724	574.3	327	12.87	150	5.91	16	0.63
<b>UCA20-M1807000</b>		M180	7	52993	82.1	7950	797.6	383	15.08	180	7.09	16	0.63

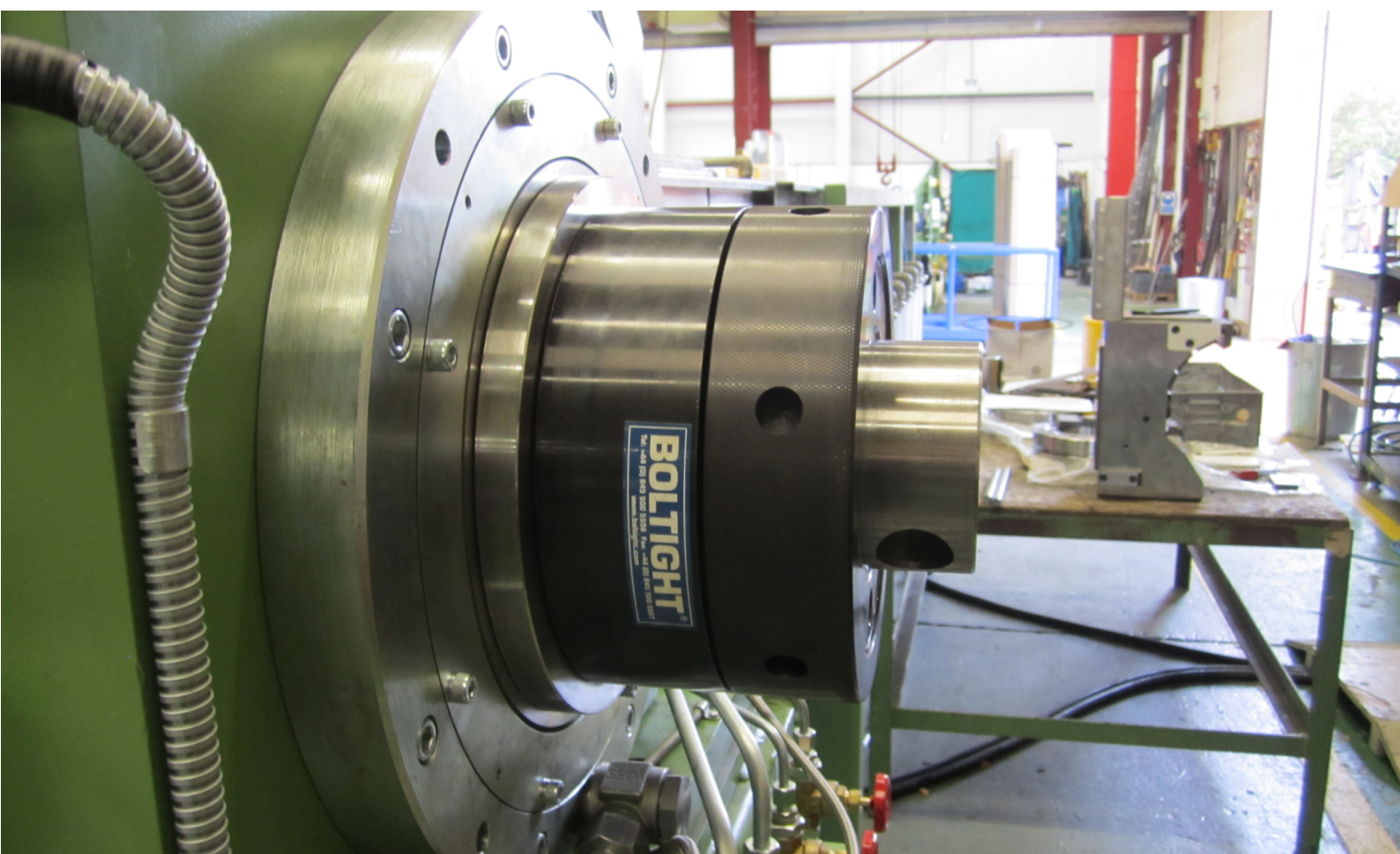

## UPPER COLLAR "TYPE B" HYDRAULIC NUT

This nut is in two parts. A plain bore load cell and a collar nut. The collar nut is threaded internally and externally, and is fitted with a load retaining, locking collar. A gap is created between the load cell body and the locking collar when the load cell is pressurised. The gap is a combination of the compression of the bolted joint and gasket, if fitted, plus the elongation of the bolt.

In use the load cell is pressurised until the hydraulic jack develops more than the desired pre-load. The locking collar is tightened. The pressure is released and the pre-load is transferred onto the locking collar threads. Due to settling of the collar threads some of the pre-load is lost. This is more critical in short bolt applications where the bolt elongation may be small. The pre-load loss on transfer to the collar becomes less significant on long grip length bolts.

Because the load cell has a plain bore the hydraulic connection can be located in the best position. The load cell can be fastened to the joint face and left in place. Similarly the hoses or rigid steel pipe-work may be permanently connected and left in place.

This nut is available to order as a custom item to customers specification.

